



Sintesis™ Advantage

Air-cooled chillers

Model CGAF SE / HE / XE
(260-700 kW – 50 Hz)



August 2020

CG-PRC051B-GB

TRANE
TECHNOLOGIES

Table of Contents

Introduction.....	3
Features and Benefits.....	4
Proven Trane Sintesis reliability	4
Close Spacing Installation	4
Factory Testing to ensure Trouble-Free Start-up.....	4
Factory-Installed and Tested Controls and Options Speed Installation	4
Micro channel condensing coils.....	5
Condenser fans.....	5
Superior Control with UC 800™ Chiller Controls	6
Application options	7
Options	7
Sound level options	8
Control options.....	8
Other Options	9
Operating Maps	10
Application Considerations.....	11
General Data	14
Water pump curves	17
Hydraulic Module	19
Acoustic data.....	20
Controls System	21
System Integration.....	22
Dimensional Data	23
Notes.....	25

Introduction

SINTESES[™] Family of chillers, heat pumps and multi-pipe units

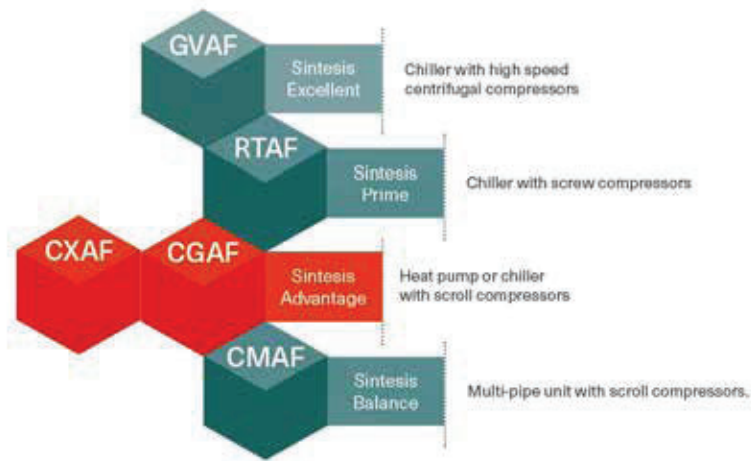

The Sintes[™] Advantage model CGAF belongs to the Trane Sintes[™] portfolio representing industry leading performance and flexibility – for a perfect fit not only to your building and application requirements, but also to your sustainability and budget targets.

The Trane Sintes[™] Advantage chiller range has been developed to minimize the Total Cost of Ownership while providing best-in-class efficiency and optimum acoustic comfort, making the Sintes[™] Advantage the perfect product for a wide range of industrial and commercial applications.

The Sintes[™] Advantage chillers, as the most versatile air-cooled scroll chiller on the HVAC market, couples great efficiency and acoustic performances with a compact design for an easy and quick installation.

All units are compliant with all applicable EU Ecodesign Regulations under the ErP framework Directive 2009/125/EC of the European Parliament.

Sintes[™] Advantage chillers are available in 3 efficiency levels and 3 acoustic packages to answer accurately to every customer's needs.

Efficiency levels

- Standard Efficiency (SE)
- High Efficiency (HE)
- Extra Efficiency (XE)

Acoustic packages

- Standard Noise (SN)
- Low Noise (LN)
- Extra Low Noise (XLN)



Features and Benefits

Proven Trane Sintesis reliability

We know how important and critical the HVAC equipment can be, therefore we design and manufacture the core components and put our system through extremely demanding performance and reliability tests.

Each unit is equipped with two or more high-efficiency hermetic, scroll compressors with Intermediate Discharge Valves (IDVs), which deliver high efficiency, especially at part load, and high reliability.

Suction-gas-cooled motor, hermetically sealed, operates at lower temperatures, allowing condensing down to 10°C and up to 68°C saturated discharge temperature, for longer motor life.

Figure 1 – CGAF inside layout



Close Spacing Installation

The Sintesis™ Advantage chiller has the tightest recommended side clearance in the industry, 1 meter, but that is not all. In situations where equipment must be installed with less clearance than recommended, which frequently occurs in retrofit applications, restricted airflow is common. Conventional chillers may not work at all. However, the Sintesis™ Advantage chiller, thanks to the Tracer UC800 with the Adaptive Control™ microprocessor will make as much chilled water as possible given the actual installed conditions, stay on-line during any unforeseen abnormal conditions, and optimize its performance. Consult your sales engineer for more details.

Factory Testing to ensure Trouble-Free Start-up

All Sintesis™ Advantage chillers are given a complete functional test at the factory. This computer-based test program completely checks the sensors, wiring, electrical components, microprocessor function, communication capability, expansion valve performance, and fans.

Where applicable, each unit is factory preset to the customer's design conditions. An example would be the leaving-liquid temperature set point. The result of this test program is that the chiller arrives at the job site fully tested and ready for operation.

Factory-Installed and Tested Controls and Options Speed Installation

All Sintesis™ Advantage chiller options, including low ambient control, ambient temperature sensor, communication interface and ice-making controls are factory installed and tested. Some manufacturers send accessories in pieces to be field installed. With Trane, the customer saves on installation expense and has assurance that ALL chiller controls and options have been tested and will function as expected.

Features and Benefits

Micro channel condensing coils

Sintesis™ Advantage chillers are equipped with micro channel condensing coils allowing excellent heat transfer and a dramatic improvement of corrosion resistance versus conventional tubes in fins coils. Micro channel coils are 100% aluminum and galvanic corrosion which can occur on condensers made with copper tubes and aluminum fins is avoided. Micro channel coils are also well adapted to dirty environments thanks to their small thickness and fins profile.

Figure 2 – Micro channel condensing coils

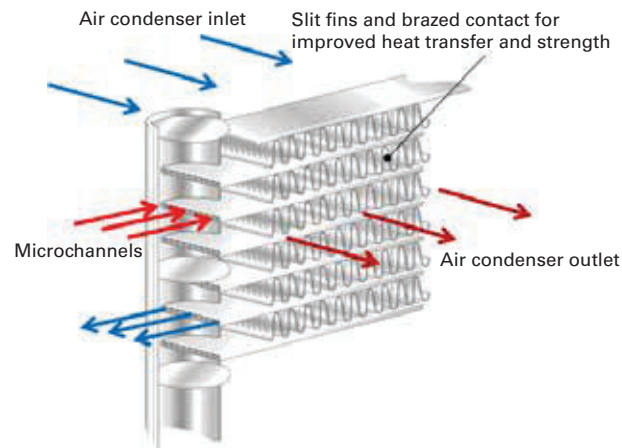

Condenser fans

Sintesis™ Advantage chillers can be equipped with AC or EC fans.

EC fans are the best option in order to reduce power consumption at full load and at part load. EC fans allow a significant reduction of sound level and a better operation of the chiller at low ambient conditions. On XLN units EC fans are equipped with special diffuser to get an air flow optimization and a quieter operation.

Figure 3 – EC fan with diffuser

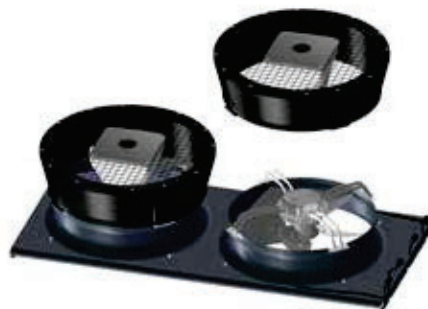

Superior Control with UC 800™ Chiller Controls

The Adaptive Control™ microprocessor system enhances the Sintesis™ Advantage chiller by providing the very latest chiller control technology. With the Adaptive Control microprocessor, unnecessary service calls and unhappy tenants are avoided. The unit does not nuisance-trip or unnecessarily shut down. Only when the Tracer chiller controls have exhausted all possible corrective actions and the unit is still violating an operating limit, will the chiller shut down. Controls on other equipment typically shut down the chiller, usually just when it is needed the most.

For Example:

A typical five-year-old chiller with dirty coils might trip out on high- pressure cutout on a 38°C [100°F] day in August. A hot day is just when comfort cooling is needed the most. In contrast, the Sintesis™ Advantage chiller with an Adaptive Control microprocessor will stage fans on, modulate the electronic expansion valve, and modulate the slide valve as it approaches a high-pressure cutout, thereby keeping the chiller on line when you need it the most, on high ambient temperatures.



Options

Application options

Ice making

The ice making option provides special control logic to handle low temperature brine applications from 20°C (68°F) down to -7°C (19.4°F) leaving evaporator temperature) for thermal storage applications.

Low temperature brine

Low temperature option provides special control logic and oil cooler is installed to handle low temperature brine applications including part load conditions below 4.4°C (40°F) down to -12°C (10.4°F) leaving evaporator temperature.

Low ambient

The low ambient option adds unit controls to allow start and operation down to ambient temperatures of -20°C (-7.2°F). High side of ambient range remains at 46°C (115°F) for standard efficiency units and 52°C (126°F) for high efficiency units.

High ambient

The high ambient option adds unit controls, oil coolers and oversized electrical components to allow start and operation up to ambient temperatures of 52°C (126°F) operation. Low side of ambient range remains at -10°C (14°F).

Wide Ambient

The wide ambient option adds unit control box ventilation and extended coil face area to allow start and operation up to ambient temperatures of 52°C (126°F) operation with low side of ambient range down to -20°C (4°F) by means of 2 speed fans or EC fan motor and compressors which have the capability to reach down to 10°C condensing temperature.

Integrated Variable Primary Flow

Integrated within the chiller controller, a variable primary flow option will allow control of the water flow through the evaporator. This will be based on a proven algorithm modulating the flow rate to minimize pump consumption at full and partial load.

The operating modes available are the Constant Differential Temperature (DT) and Adjustable Fixed Speed.

Constant differential temperature (DT)

The unit will be equipped with a pump package driven by a speed inverter. The modulation of the pump speed is managed to ensure that chiller DT stays constant.

Entering and leaving temperatures at the evaporator will be measured directly by the chiller controller, through the factory-supplied sensor. A DT set point will be present on the unit controller. The option for constant DT is intended to be used with 3-way valves on water systems, or 2-way valves on water system but constant flow at the by-pass. The minimum pump frequency can be adjusted on the inverter.

Partial and Total Heat Recovery

Heat recovery appears more and more as a sensible response to offset energy costs continually on the rise. The Trane Sintesis™ Advantage chillers with Partial and Total Heat Recovery option combines the energy savings of heat recovery operation with the installation and maintenance cost savings of completely factory packaged air cooled liquid chillers.

The CGAF with Heat Recovery option re-uses the waste heat generated during the cooling cycle, instead of exhausting it to the atmosphere, allowing the unit to operate as a standard chiller as long as heat is not required or it can simultaneously produce chilled and hot water which can be used for applications like: Heating or preheating of boiler systems or domestic cater, Air conditioning/ventilation air pre-heat, and Industrial processes.

The Heat Recovery Exchanger is a brazed plate heat exchanger or decoupling bottle, connected to the compressor discharge line, and sized to recover up to 25% of the nominal cooling capacity for Partial Heat Recovery and 100% of the nominal cooling capacity for Total Heat Recovery.

The Heat Recovery Exchanger is not suited for Food and Beverage applications. The use of a primary loop is mandatory.

The amount of net heat recovery depends on:

- the percentage of cooling load available
- the ambient temperature

Direct Free-cooling

In order to optimize operating costs of Sintesis™ Advantage chillers even more, they can be equipped with Direct Free-Cooling option.

This system can drastically reduce the operating costs, especially in winter cooling conditions. The principle is simple: when the outdoor temperature reaches below a certain point, the free cooling system will partially or totally offset the mechanical system by using the outdoor air to cool the water in the system. Additionally, by making less use of compressors over the year, the unit lifetime can be extended.

The advantages of this type of application are:

- A small footprint compared to a system where a dry cooler and a chiller are used
- One single equipment control
- A wide range of capacities

The Sintesis™ Advantage Series, CGAF Free Cooling are designed for countries that have a significant yearly number of hours below 0 °C and for applications where cooling is needed all year round.

Sound level options

Low noise (LN)

Low noise units are equipped with a jacket on the oil separators and a pre-formed 'sound box' encapsulating each compressor.

Extra low noise (XLN)

Extra low noise units are equipped with a jacket on the oil separators, a pre-formed 'sound box' encapsulating each compressor and EC fans with diffusers.

Night Noise Setback (NNSB)

Night noise set back allow to reduce the sound level of the chiller by reducing the speed of dual speed AC or EC fans controlled with an external on/off contact.

Electrical options

Under over voltage protection IP20 internal protection. Flow switch: the flow switch is sent as an accessory and has to be installed on site.

Integrated hydraulic module option*

Hydraulic module includes the following components: water strainer, expansion vessel 80l, pressure relief valve set at 5 bars, twin pump low head allowing a pressure drop in the water circuit up to 120kPa or twin pump high head allowing a pressure drop in the water circuit up to 220kPa, balancing valve and anti-freeze protection.

Control options

BACnet™ MSTP communications interface

Allows the user to easily interface with BACnet via a single twisted pair wiring to a factory installed and tested communication board.

LonTalk™ (LCI-C) Communications Interface

Provides the LonMar chiller profile inputs/outputs for use with a generic building automation system via a single twisted pair wiring to a factory installed and tested communication board.

ModBus™ RTU Communications Interface

Allows the user to easily interface with ModBus via a single twisted pair wiring to a factory installed and tested communication board.

External chilled water setpoint

UC800 accepts either a 2-10 VDC or a 4-20mA input signal, to adjust the chilled water setpoint from a remote location.

External current limit setpoint

UC800 accepts either a 2-10VDC or a 4-20mA input signal to adjust the current limit setpoint from a remote location.



Options

Ice making contact

UC800 provides an output contact closure that can be used as a signal to the system that ice building is in operation. This relay will be closed when ice building is in progress and open when ice building has been terminated by either UC800 or the remote interlock. It is used to signal the system changes required to convert to and from ice making.

Run test report

Run test report gives the results of the performance test of the unit in the design conditions specified in the order write up with water without glycol.

The data recorded are: cooling capacity, power input, air temperature, water entering temperature, water leaving temperature and water flow.

* Components may differ depending on unit model and size. Contact your local sales office for details.

Other Options

Relief valves

Dual relief valve plus 3 way valve on high pressure side.

Evaporator without insulation

Evaporator is not insulated and a specific insulation can be done on site.

Coated condensing coils

Condensing coils are protected with a cathodic epoxy electro deposition coating UV resistant.

Neoprene pads

Neoprene pads avoid a direct contact of the base of the unit with the ground.

Neoprene isolators

Isolators provide isolation between chiller and structure to help eliminate vibration transmission and have an efficiency of 95% minimum.

Grooved pipe plus weld coupling

Grooved pipes are connected on water inlet and outlet, the cooling allows the connection between the grooved pipe and the evaporator water connection.

Export shipping package

Metallic clog are fixed on the base frame of the unit. It prevents direct contact between the chiller and the container while loading and unloading from the container.

Disconnect with circuit breaker

The unit is equipped with a circuit breaker for each circuit and a centralized connecting block for the 3 phases.

Operating Maps

CGAF chillers can be configured to operate according to a wide operating temperature range, suitable for comfort and process needs.

Table 1 – CGAF operating ranges

	Leaving water temperature		Entering air temperature	
	Min	Max	Min	Max
Standard ambient (SE or HE)	-12°C	+18°C	-10°C	+47°C
High ambient (HE or XE)	-12°C	+18°C	-10°C	+52°C
Low ambient (XE or option)	-12°C	+18°C	-20°C	+47°C
Wide ambient (XE)	-12°C	+18°C	-20°C	+52°C

Operating map - SE version

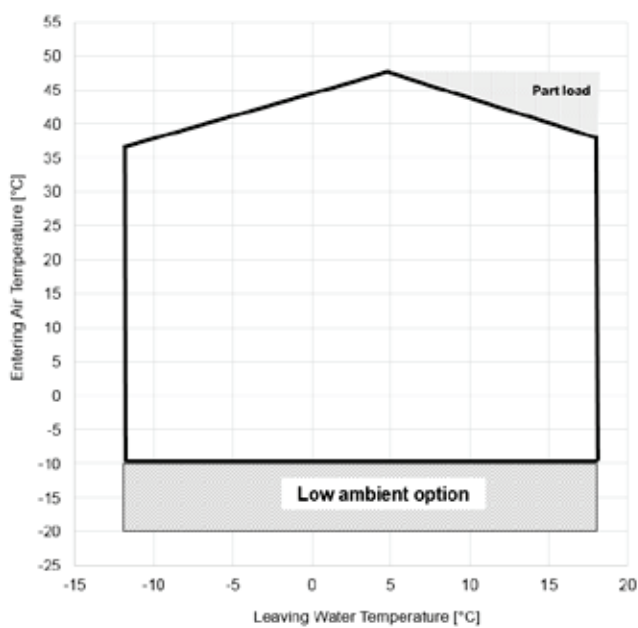

Operating map - XE version

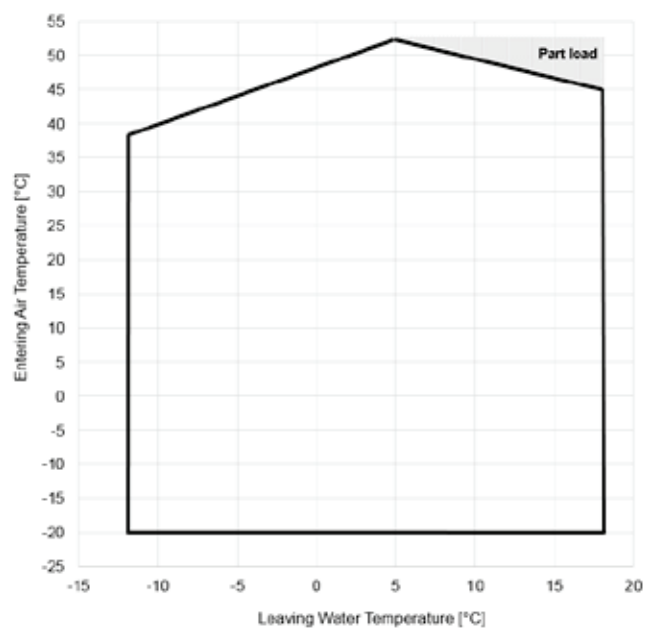

Operating map - HE version

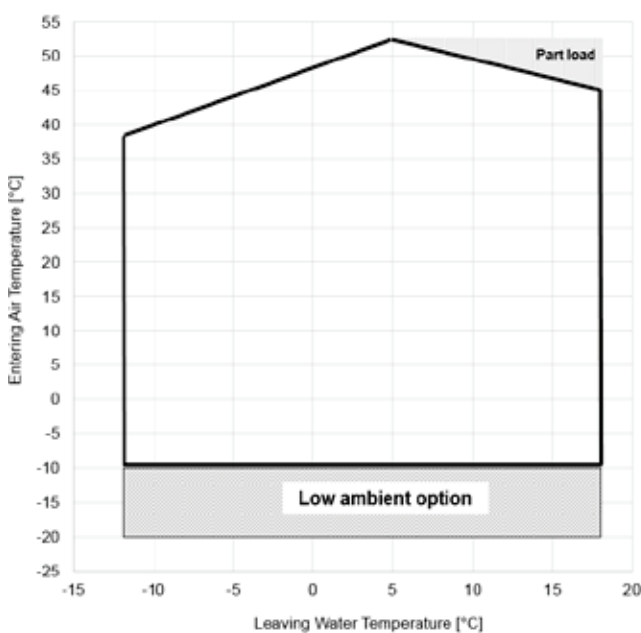

Application Considerations

Figure 4 – Flow rate Out of Range

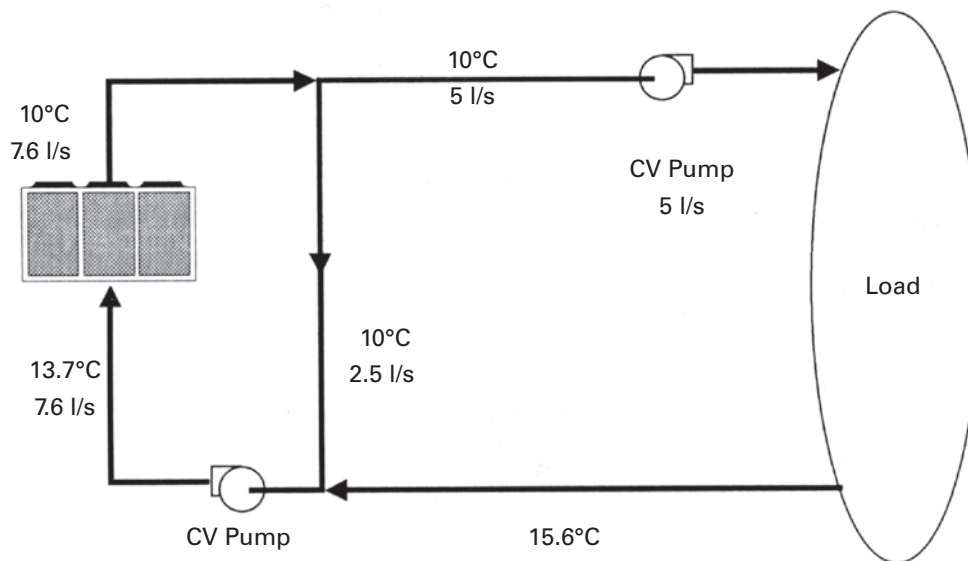

Important

Certain application constraints should be considered when sizing, selecting, and installing Trane Sintesis™ chillers. Unit and system reliability is often dependent on properly and completely complying with these considerations. When the application varies from the guidelines presented, it should be reviewed with your local sales engineer.

Unit Sizing

Unit capacities are listed in the performance data section. Intentionally oversizing a unit to ensure adequate capacity is not recommended. Erratic system operation and excessive compressor cycling are often a direct result of an oversized chiller. In addition, an oversized unit is usually more expensive to purchase, install, and operate. If oversizing is desired, consider using two units.

Water Treatment

Dirt, scale, products of corrosion, and other foreign material will adversely affect heat transfer between the water and system components. Foreign matter in the chilled-water system can also increase pressure drop and, consequently, reduce water flow. Proper water treatment must be determined locally, depending on the type of system and local water characteristics. Neither salt nor brackish water is recommended for use in Trane Sintesis™ Advantage chillers. Use of either will lead to a shortened chiller life. Trane encourages the employment of a reputable water-treatment specialist, familiar with local water conditions, to assist in this determination and in the establishment of a proper water-treatment program.

Effect of Altitude on Capacity

Sintesis™ Advantage chillers capacities given in the performance data tables, are for use at sea level. At elevations substantially above sea level, the decreased air density will reduce condenser capacity and, therefore, unit capacity and efficiency.

Ambient Limitations

Trane Sintesis™ Advantage chillers are designed for year-round operation over a range of ambient temperatures. The Sintesis™ Advantage chiller will operate in ambient temperatures of -10 to 46°C [14 to 115°F]. Selecting the high-ambient option will allow the chiller to operate in ambient temperatures of 55°C [131°F], and selecting the low-ambient option will increase the operational capability of the water chiller to ambient temperatures as low as -20°C [-4°F]. For operation outside of these ranges, contact the local sales office.

Water Flow Limits

The minimum water flow rates are given in the Installation and Operation Manual. Evaporator flow rates below the tabulated values will result in laminar flow and cause freeze-up problems, scaling, stratification, and poor control. The maximum evaporator water flow rate is also given in the general data section. Flow rates exceeding those listed may result in excessive tube erosion.

Application Considerations

Flow Rates Out of Range

Many process cooling jobs require flow rates that cannot be met with the minimum and maximum published values within the Model Sintesis evaporator. A simple piping change can alleviate this problem. For example: A plastic injection molding process requires 5.0 l/s [80 gpm] of 10°C [50°F] water and returns that water at 15.6°C [60°F]. The selected chiller can operate at these temperatures, but has a minimum flow rate of 7.6 l/s [120 gpm]. The following system can satisfy the process.

Flow Control

Trane requires the chilled water flow control in conjunction with the Sintesis Chiller to be done by the chiller. This will allow the chiller to protect itself in potentially harmful conditions.

Leaving-Water Temperature Limits

Trane air-cooled Sintesis™ Series chillers have three distinct leaving-water categories: standard, low temperature, and ice making. The standard leaving- solution temperature range is 4.4 to 18°C [40 to 65°F]. Low-temperature machines produce leaving-liquid temperatures less than 4.4°C [40°F]. Since liquid supply temperature set points less than 4.4°C [40°F] result in suction temperatures at or below the freezing point of water, a glycol solution is required for all Low - temperature machines. Ice-making machines have a leaving-liquid temperature range of -12 to 20°C [10.5 to 68°F]. Ice-making controls include dual set point controls and safeties for ice making and comfort cooling capabilities. Consult your local sales engineer for applications or selections involving low temperature or ice making machines. The maximum water temperature that can be circulated through an evaporator when the unit is not operating is 55°C [131°F].

Supply-Water Temperature Drop

The performance data for the Trane Sintesis™ Advantage chiller is based on a chilled-water temperature drop of 6°C [10.8°F]. Chilled-water temperature drops from 3.3 to 10°C [6 to 18°F] may be used as long as minimum and maximum water temperature, and minimum and maximum flow rates, is not violated. Temperature drops outside this range are beyond the optimum range for control, and may adversely affect the microcomputer's ability to maintain an acceptable supply-water temperature range. Further, temperature drops of less than 3.3°C [6°F] may result in inadequate refrigerant superheat. Sufficient superheat is always a primary concern in any direct- expansion refrigerant system and is especially important in a package chiller where the evaporator is closely coupled to the compressor. When temperature drops are less than 3.3°C [6°F], an evaporator runaround loop may be required.

Figure 5 – Flow rate Out of Range

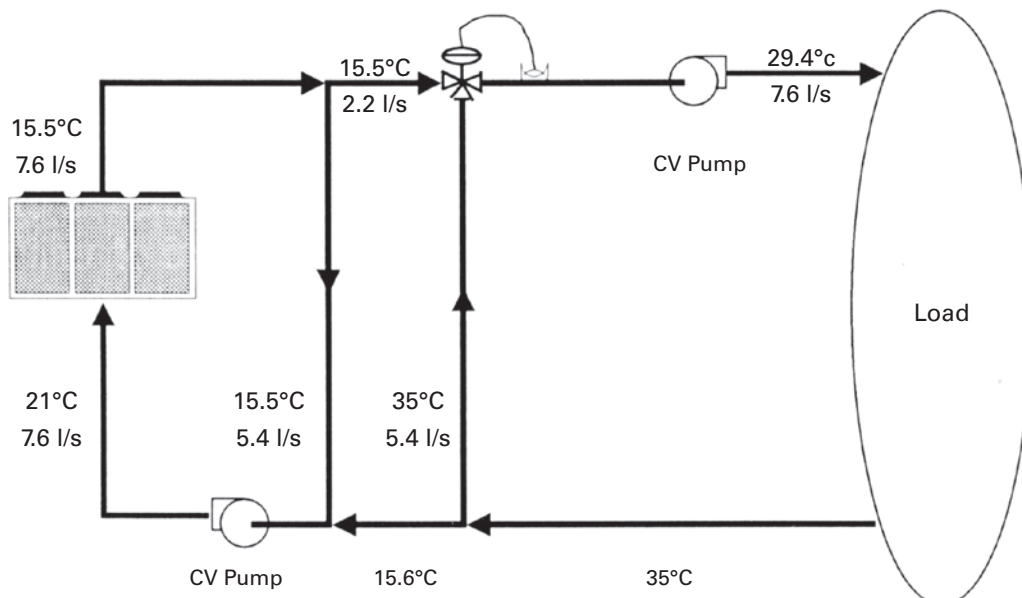



Application Considerations

Ice Storage

Reduced Electrical Demand an ice-storage system uses a standard chiller to make ice at night, when utilities charge less for electricity. The ice supplements, or even replaces, mechanical cooling during the day, when utility rates are at their highest. This reduced need for cooling results in big utility cost savings.

Another advantage of ice storage is standby cooling capacity. If the chiller is unable to operate, one or two days of ice may still be available to provide cooling. In that period of time, the chiller can be repaired before building occupants feel any loss of comfort.

The Trane Sintesis™ Model CGAF chiller is uniquely suited to low-temperature applications like ice storage because of the ambient relief experienced at night. This allows the Model Sintesis™ chiller to produce ice efficiently, with less stress on the machine.

Simple and smart control strategies are another advantage the Model Sintesis™ Advantage chiller offers for ice-storage applications. Trane UC 800 building management systems can actually anticipate how much ice needs to be made at night, and operate the system accordingly.

The controls are integrated right into the chiller. Two wires and preprogrammed software dramatically reduce field installation cost and complex programming.

Short Water Loops

The proper location of the temperature control sensor is in the supply (outlet) water connection or pipe.

This location allows the building to act as a buffer and assures a slowly-changing return- water temperature. If there is not a sufficient volume of water in the system to provide an adequate buffer, temperature control can be lost, resulting in erratic system operation and excessive compressor cycling. A short water loop has the same effect as attempting to control using the building return water. Typically, a two-minute water loop is sufficient.

To prevent a short water loop. Therefore, as a guideline, ensure that the volume of water in the evaporator loop equals or exceeds two times the evaporator flow rate per minute. For a rapidly changing load profile, the amount of volume should be increased. To prevent the effect of a short water loop, the following item should be given careful consideration: a storage tank or larger header pipe to increase the volume of water in the system and, therefore, reduce the rate of change of the return water temperature.

Application Types

- Comfort cooling
- Industrial process cooling
- Ice or thermal storage
- Low-temperature process cooling.

General Data

Table 2 – General Data CGAF Standard Efficiency sizes 090 – 190

CGAF Standard Efficiency (SE) (1)		090	100	110	130	140	150	165	180	190
Cooling capacity (3)	(kW)	318	351	391	431	468	468	553	621	661
Total power input (3)	(kW)	105	119	138	157	162	169	204	211	230
EER		3.04	2.94	2.83	2.74	2.89	2.78	2.71	2.94	2.88
Eurovent Efficiency Class - cooling		B	B	C	C	B	C	C	B	C
SEER	(kW/kW)	4.17	4.13	4.18	4.13	4.21	4.22	4.30	4.32	4.31
Seasonal space cooling efficiency η_{sc}	(%)	164	162	164	162	166	166	169	170	169
Acoustic data (2)										
Sound power level (SN)	(dBA)	92	94	95	95	94	95	96	97	97
Sound power level (LN)	(dBA)	89	90	91	92	91	92	92	93	94
Sound power level (XLN)	(dBA)	87	88	89	89	89	89	90	91	91
Condenser fans										
Number of condenser fans	#	6	6	6	6	8	8	8	10	10
Fan motor / type - AC fixed speed motor										
Airflow per fan	m ³ /h	15859	15778	15680	15580	15686	15684	15609	15730	15670
Max Power Input per Motor	kW	1.44	1	1	1	1	1	1	1	1
Max Amps per Motor	A	2.9	3	3	3	3	3	3	3	3
Fan motor / type - EC variable speed motor										
Airflow per fan	m ³ /h	17410.86	17331	17235	17136	17240	17239	17165	17283	17225
Max Power Input per Motor	kW	1.95	2	2	2	2	2	2	2	2
Max Amps per Motor	A	3	3	3	3	3	3	3	3	3
General data										
Number of refrigerant circuits		2	2	2	2	2	2	2	2	2
Refrigerant type		R410A								
Compressor Number per Circuit	#	2	2	2	2	3	3	3	3	3
Compressor type		Scroll	Scroll	Scroll	Scroll	Scroll	Scroll	Scroll	Scroll	Scroll
Evaporator type		Stainless steel / copper brazed plate heat exchanger								
Evaporator water content volume	(l)	31	36	40	49	49	57	65	73	81
Condenser type		Full aluminum Micro channel heat exchanger								
Number of condenser coils	#	6	6	6	6	8	8	8	10	10
Nominal water connection size (Grooved coupling)	(in) - (mm)	4" - 114.3	4" - 114.3	4" - 114.3	4" - 114.3	5" - 139.7	5" - 139.7	5" - 139.7	5" - 139.7	5" - 139.7
Hydraulic module data										
Single pump - Standard head pressure option										
Max available Head Pressure	(kPa)	123	115	98	92	142	137	124	164	155
Motor Power	(kW)	6	6	8	8	8	8	11	11	11
Rated Amps	(A)	11	11	14	14	14	14	21	21	21
Single pump - High head pressure option										
Max available Head Pressure	(kPa)	251	247	234	232	249	252	245	234	226
Motor Power	(kW)	11	11	11	11	15	15	15	15	15
Rated Amps	(A)	21	21	21	21	28	28	28	28	28
Dual pump - Standard head pressure option										
Max available Head Pressure	(kPa)	123	115	98	92	142	137	124	164	155
Motor Power	(kW)	6	6	8	8	8	8	11	11	11
Rated Amps	(A)	11	11	14	14	14	14	21	21	21
Dual pump - High head pressure option										
Max available Head Pressure	(kPa)	251	247	234	232	249	252	245	234	226
Motor Power	(kW)	11	11	11	11	15	15	15	15	15
Rated Amps	(A)	21	21	21	21	28	28	28	28	28
Expansion Tank Volume	(l)	50	50	50	50	50	50	50	50	50
Buffer tank volume (optional)	(l)	607	607	607	607	777	777	777	777	777
Antifreeze Heater without pump package and without buffer tank	(W)	360	420	420	420	540	640	640	640	640
Antifreeze Heater with pump package and without buffer tank	(W)	840	900	900	900	1080	1180	1180	1180	1180
Antifreeze Heater with pump package and with buffer tank	(W)	1820	1880	1880	1880	2630	2730	2730	2730	2730

(1) Performances at Eurovent rating conditions: 12/7°C entering/leaving water temperature and 35°C ambient temperature according to EN 14511-2013.
(2) At Eurovent conditions, with 1pW reference sound power, according to ISO9614.

General Data

Table 3 – General Data CGAF High Efficiency sizes 080 – 190

CGAF High Efficiency (HE) (1)		080	090	100	110	130	140	150	165	180	190
Cooling capacity (3)	(kW)	293	334	371	416	459	498	548	587	641	682
Total power input (3)	(kW)	90	102	115	132	149	155	176	194	205	222
EER		3.25	3.28	3.22	3.16	3.09	3.21	3.11	3.03	3.12	3.07
Eurovent Efficiency Class - cooling		A	A	A	A	B	A	A	B	A	B
SEER	(kW/ kW)	4.36	4.31	4.34	4.39	4.46	4.26	4.30	4.42	4.39	4.39
Seasonal space cooling efficiency η_{sc}	(%)	171	169	171	172	175	167	169	174	172	173
Acoustic data (2)											
Sound power level (SN)	(dBA)	89	92	94	95	95	94	95	96	97	97
Sound power level (LN)	(dBA)	87	90	91	92	92	91	92	93	94	94
Sound power level (XLN)	(dBA)	86	88	89	89	90	89	90	90	91	91
Condenser fans											
Number of condenser fans	#	6	8	8	8	8	10	10	10	12	12
Fan motor / type - AC fixed speed motor											
Airflow per fan	m ³ /h	15925	16020	15956	15879	15803	15840	15839	15782	15858	15809
Max Power Input per Motor	kW	1.4	1.4	1.4	1.4	1.4	1.4	1.4	1.4	1.4	1.4
Max Amps per Motor	A	3	3	3	3	3	3	3	3	3	3
Fan motor / type - EC variable speed motor											
Airflow per fan	m ³ /h	900	900	900	900	900	900	900	900	900	900
Max Power Input per Motor	kW	2.0	2.0	2.0	2.0	2.0	2.0	2.0	2.0	2.0	2.0
Max Amps per Motor	A	3	3	3	3	3	3	3	3	3	3
General data											
Number of refrigerant circuits		2	2	2	2	2	2	2	2	2	2
Refrigerant type		R410A									
Compressor Number per Circuit	#	2	2	2	2	2	3	3	3	3	3
Compressor type		Scroll									
Evaporator type		Stainless steel / copper brazed plate heat exchanger									
Evaporator water content volume	(l)	40.4	40	49	57	65	73	81	81	81	86
Condenser type		Full aluminum Micro channel heat exchanger									
Number of condenser coils	#	6	8	8	8	8	10	10	10	12	12
Nominal water connection size (Grooved coupling)	(in) - (mm)	4" - 114.3	4" - 114.3	4" - 114.3	4" - 114.3	4" - 114.3	5" - 139.7	5" - 139.7	5" - 139.7	5" - 139.7	5" - 139.7
Hydraulic module data											
Single pump - Standard head pressure option											
Max available Head Pressure	(kPa)	155	136	119	103	92	146	134	122	161	149
Motor Power	(kW)	5.5	6	6	8	8	8	8	11	11	11
Rated Amps	(A)	11	11	11	14	14	14	14	21	21	21
Single pump - High head pressure option											
Max available Head Pressure	(kPa)	280	266	254	242	237	257	253	249	231	220
Motor Power	(kW)	11	11	11	11	11	15	15	15	15	15
Rated Amps	(A)	20.8	21	21	21	21	28	28	28	28	28
Dual pump - Standard head pressure option											
Max available Head Pressure	(kPa)	155	136	119	103	92	146	134	122	161	149
Motor Power	(kW)	5.5	6	6	8	8	8	8	11	11	11
Rated Amps	(A)	11	11	11	14	14	14	14	21	21	21
Dual pump - High head pressure option											
Max available Head Pressure	(kPa)	280	266	254	242	237	257	253	249	231	220
Motor Power	(kW)	11	11	11	11	11	15	15	15	15	15
Rated Amps	(A)	21	21	21	21	21	28	28	28	28	28
Expansion Tank Volume	(l)	50	50	50	50	50	50	50	50	50	50
Buffer tank volume (optional)	(l)	607	607	607	607	607	777	777	777	777	777
Antifreeze Heater without pump package and without buffer tank	(W)	420	420	420	520	520	640	640	640	640	640
Antifreeze Heater with pump package and without buffer tank	(W)	900	900	900	1000	1000	1180	1180	1180	1180	1180
Antifreeze Heater with pump package and with buffer tank	(W)	1880	1880	1880	1980	1980	2730	2730	2730	2730	2730

(1) Performances at Eurovent rating conditions: 12/7°C entering/leaving water temperature and 35°C ambient temperature according to EN 14511-2013.

(2) At Eurovent conditions, with 1pW reference sound power, according to ISO9614.

General Data

Table 4 – General Data CGAF Extra High Efficiency sizes 080 – 190

CGAF Extra High Efficiency (XE) (1)	080	090	100	110	130	140	150	165	180	190
Cooling capacity - Standard & Low noise (kW)	297	333	374	423	471	505	560	604	653	699
Cooling capacity - Extra low noise (kW)	295	333	374	419	464	502	553	593	647	689
Total power input - Standard & Low noise (kW)	88	99	112	128	144	151	172	188	200	216
Total power input - Extra Low noise (kW)	87	99	112	127	144	150	171	188	199	215
EER	4.72	4.81	4.67	4.69	4.67	4.91	4.77	4.75	4.84	4.80
Eurovent Efficiency Class - cooling	A	A	A	A	A	A	A	A	A	A
SEER (kW/kW)	4.87	4.92	4.79	4.75	4.77	5.03	4.89	4.87	4.95	4.91
Seasonal space cooling efficiency η _{sc} (%)	192	194	189	187	188	198	193	192	195	193
Acoustic data (2)										
Sound power level (SN) (dBA)	90	92	94	95	96	94	96	96	97	98
Sound power level (LN) (dBA)	88	90	91	92	93	91	93	94	94	95
Sound power level (XLN) (dBA)	85	87	88	89	89	88	89	90	90	91
Condenser fans										
Number of condenser fans #	6	8	8	8	8	10	10	10	12	12
Fan motor / type Variable speed EC motor										
Airflow per fan (m ³ /h)	17476	17569	17506	17430	17355	17392	17391	17335	17410	17362
Max Power Input per Motor (kW)	2.0	2.0	2.0	2.0	2.0	2.0	2.0	2.0	2.0	2.0
Max Amps per Motor (A)	3	3	3	3	3	3	3	3	3	3
General data										
Number of refrigerant circuits	2	2	2	2	2	2	2	2	2	2
Refrigerant type	R410A									
Compressor Number per Circuit #	2	2	2	2	2	3	3	3	3	3
Compressor type	Scroll									
Evaporator type	Stainless steel / copper brazed plate heat exchanger									
Evaporator water content volume (l)	40.4	40	49	57	65	73	81	81	81	86
Condenser type	Full aluminum Micro channel heat exchanger									
Number of condenser coils #	6	8	8	8	8	10	10	10	12	12
Nominal water connection size (in) - (mm)	4" - 114.3	4" - 114.3	4" - 114.3	4" - 114.3	4" - 114.3	5" - 139.7	5" - 139.7	5" - 139.7	5" - 139.7	5" - 139.7
Hydraulic module data										
Single pump - Standard head pressure option										
Max available Head Pressure (kPa)	155	136	119	103	92	146	134	122	161	149
Motor Power (kW)	5.5	6	6	8	8	8	8	11	11	11
Rated Amps (A)	11	11	11	14	14	14	14	21	21	21
Single pump - High head pressure option										
Max available Head Pressure (kPa)	280	266	254	242	237	257	253	249	231	220
Motor Power (kW)	11	11	11	11	11	15	15	15	15	15
Rated Amps (A)	20.8	21	21	21	21	28	28	28	28	28
Dual pump - Standard head pressure option										
Max available Head Pressure (kPa)	155	136	119	103	92	146	134	122	161	149
Motor Power (kW)	5.5	6	6	8	8	8	8	11	11	11
Rated Amps (A)	11	11	11	14	14	14	14	21	21	21
Dual pump - High head pressure option										
Max available Head Pressure (kPa)	280	266	254	242	237	257	253	249	231	220
Motor Power (kW)	11	11	11	11	11	15	15	15	15	15
Rated Amps (A)	21	21	21	21	21	28	28	28	28	28
Expansion Tank Volume (l)	50	50	50	50	50	50	50	50	50	50
Buffer tank volume (optional) (l)	607	607	607	607	607	777	777	777	777	777
Antifreeze Heater without pump package and without buffer tank (W)	420	420	420	520	520	640	640	640	640	640
Antifreeze Heater with pump package and without buffer tank (W)	900	900	900	1000	1000	1180	1180	1180	1180	1180
Antifreeze Heater with pump package and with buffer tank (W)	1880	1880	1880	1980	1980	2730	2730	2730	2730	2730

(1) Performances at Eurovent rating conditions: 12/7°C entering/leaving water temperature and 35°C ambient temperature according to EN 14511-2013.
(2) At Eurovent conditions, with 1pW reference sound power, according to ISO9614.

Water pump curves

Figure 6 – Pump curve – CGAF 080 -190 Standard Efficiency/High Efficiency/ Extra high efficiency

SE version - Dual Pump Standard Head - sizes 090 to 140

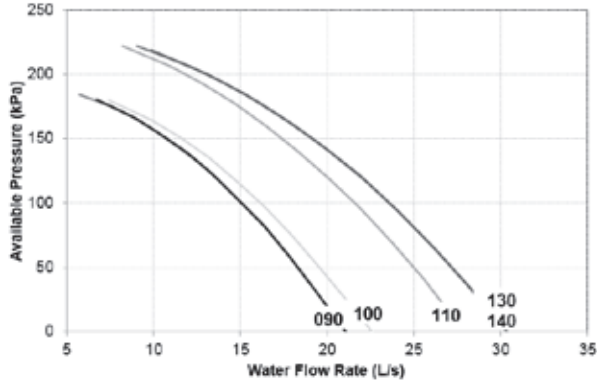

SE version - Dual Pump Standard Head - sizes 150 to 190

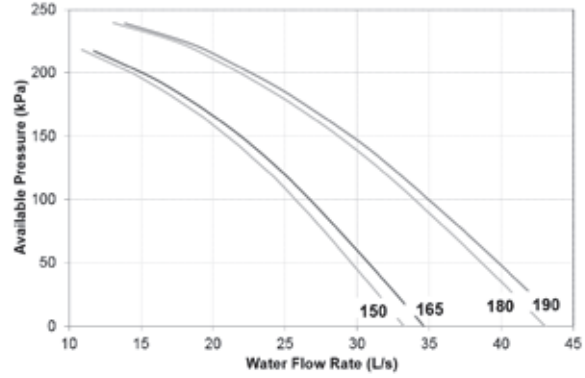

SE version - Dual Pump High Head - sizes 090 to 140

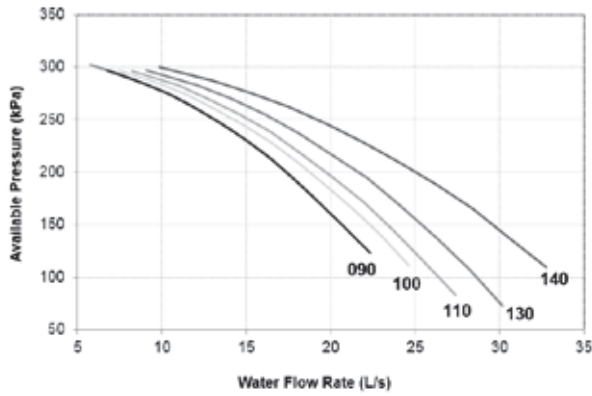

SE version - Dual Pump High Head - sizes 150 to 190

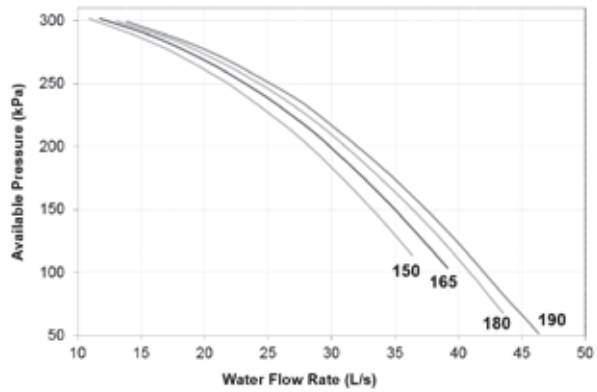

HE/XE version - Dual Pump Standard Head - sizes 080 to 140

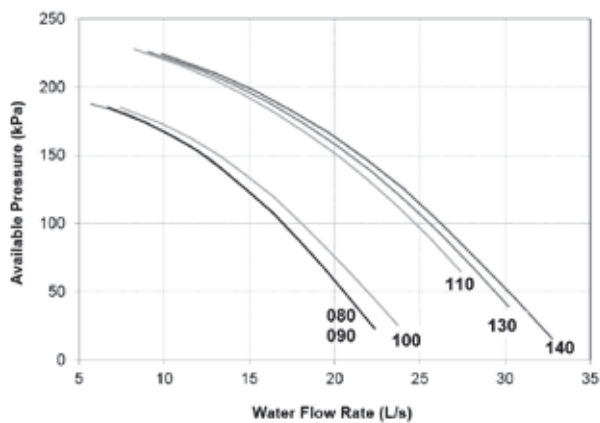

HE/XE version - Dual Pump Standard Head - sizes 150 to 190

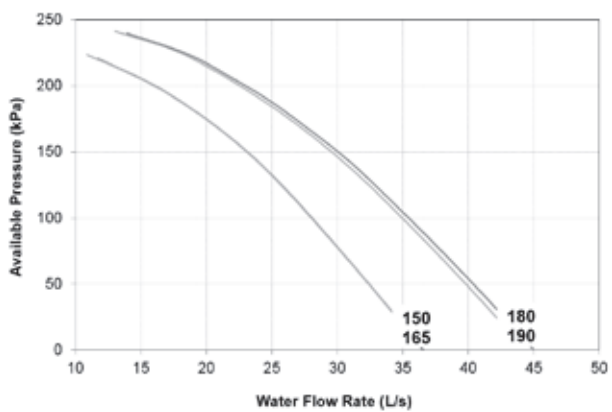

HE/XE version - Dual Pump High Head - sizes 080 to 140

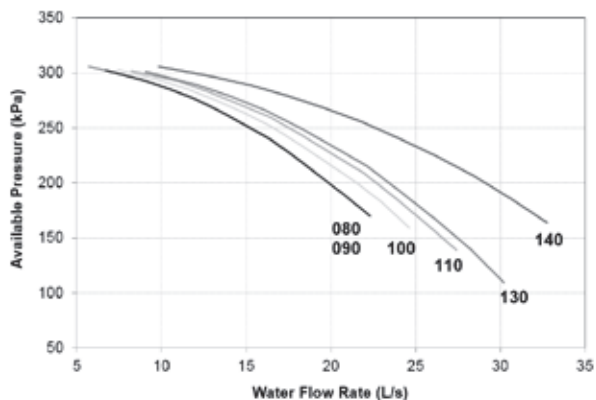

HE/XE version - Dual Pump High Head - sizes 150 to 190

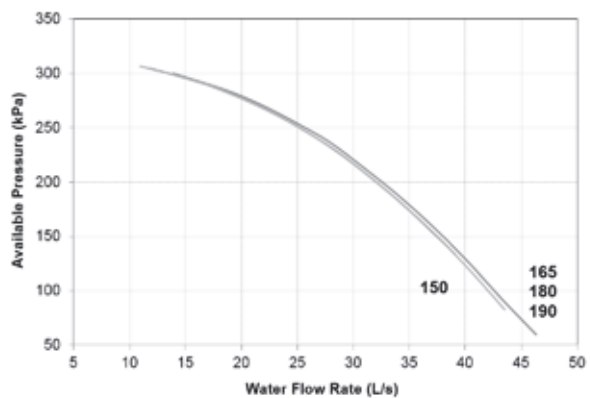

Water pump curves

Figure 7 – Water pressure drop heat exchanger – CGAF 080-190 Standard Efficiency/High Efficiency/ Extra high efficiency

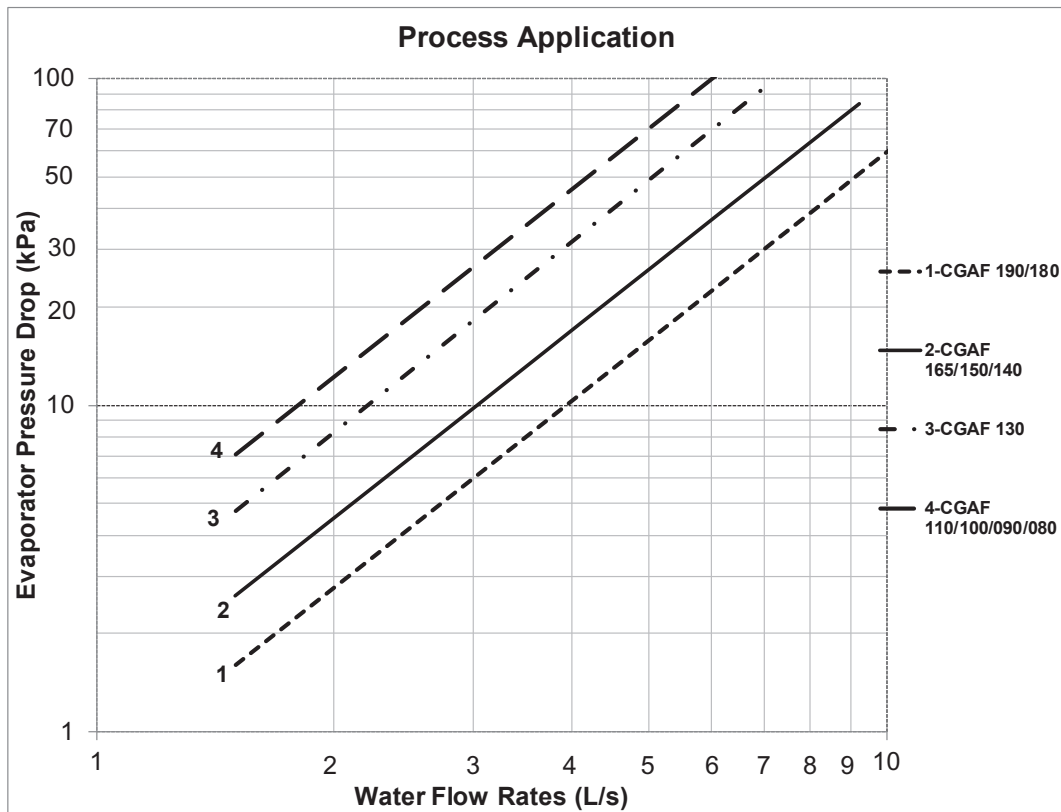
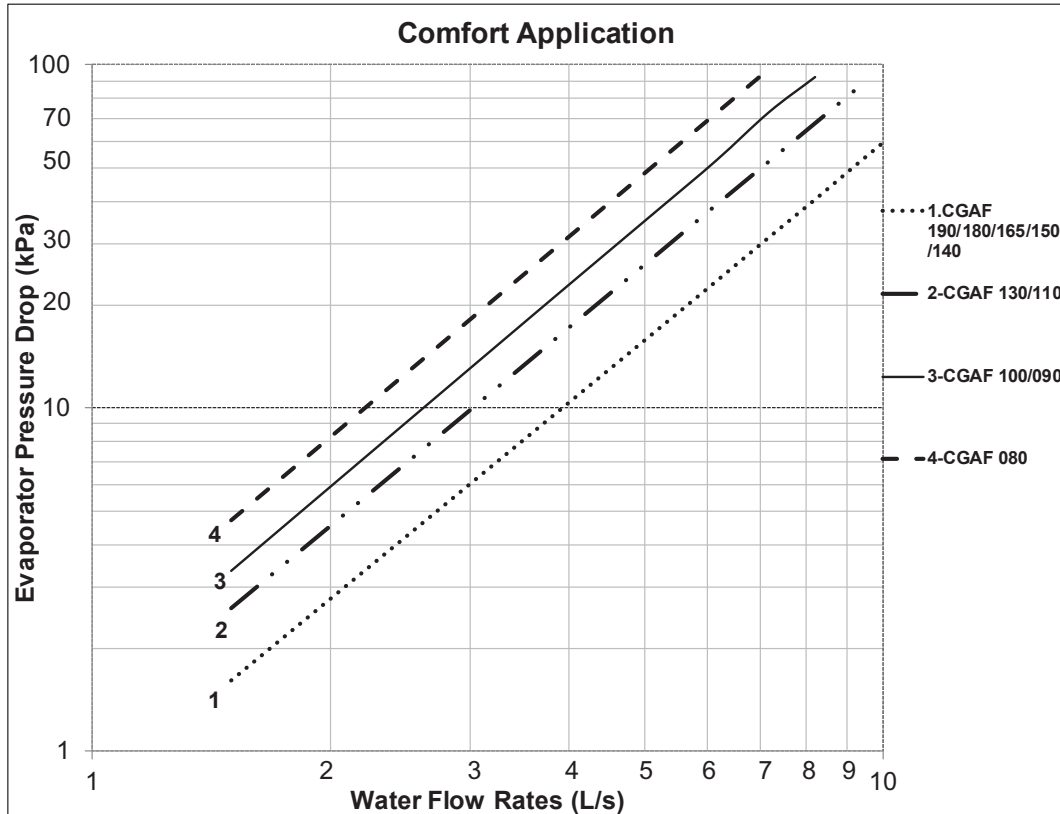

Hydraulic Module

The hydraulic module includes*:

- Water strainer to protect the water circuit against fouling
- 80l expansion vessel
- Pressure relief valve set at 5 bars, to protect the water circuit against over pressure
- Twin pump low head or twin pump high end
- Balancing valve to adjust the water flow
- Freeze protection

* Components may differ depending on unit model and size. Contact your local sales office for details.

Figure 8 – Hydraulic module option

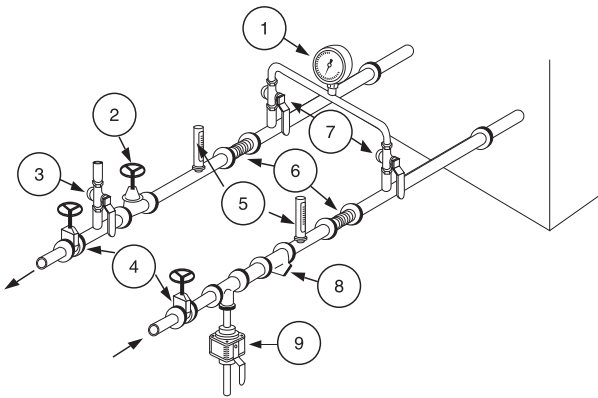

- 1 = Pressure gauges: show entering and leaving water pressure.
 2 = Balancing valve: adjusts water flow.
 3 = Air purge allows to remove the air from the water circuit during fill up.
 4 = Stop valves: isolate chillers and water circuiting pump during maintenance operations.
 5 = Thermometers: indicate chilled water entering and leaving temperatures.
 6 = Expansion compensators: avoid mechanical stress between chiller and piping installation.
 7 = Stop valve located on the outlet connection: used to measure the water pressure inlet or outlet of evaporator.

Acoustic data

Table 5 – Sound power levels dB(A) in accordance with ISO 9614 - 1996. (1)

	Standard Efficiency (SE)			High Efficiency (HE)			Extra High Efficiency (XE)		
	SN	LN	XLN	SN	LN	XLN	SN	LN	XLN
80	-	-	-	89	87	86	90	88	85
90	92	89	87	92	90	88	92	90	87
100	94	90	88	94	91	89	94	91	88
110	95	91	89	95	92	89	95	92	89
130	95	92	89	95	92	90	96	93	89
140	94	91	89	94	91	89	94	91	88
150	95	92	89	95	92	90	96	93	89
165	96	92	90	96	93	90	96	94	90
180	97	93	91	97	94	91	97	94	90
190	97	94	91	97	94	91	98	95	91

Table 6 – Sound pressure levels dB(A) at 10m (2)

	Standard Efficiency (SE)			High Efficiency (HE)			Extra High Efficiency (XE)		
	SN	LN	XLN	SN	LN	XLN	SN	LN	XLN
80	-	-	-	57	55	54	58	56	53
90	60	57	55	60	58	56	60	58	55
100	62	58	56	62	59	57	62	59	56
110	63	59	57	63	60	57	63	60	57
130	63	60	57	63	60	58	64	61	57
140	62	59	57	62	59	57	62	59	56
150	63	60	57	63	60	58	64	61	57
165	64	60	58	64	61	58	64	62	58
180	65	61	59	64	61	58	64	61	57
190	65	62	59	64	61	58	65	62	58

Notes:

At Eurovent conditions: 12/7°C entering/leaving water temperature and 35°C ambient temperature:

(1) Value at full load with 1pW Reference Sound Power, according to ISO9614.

(2) Average at 10 meters in a free field. This is a non-contractual data, calculated from the above certified sound power level according to the formula $L_p = L_w - 10 \log S$. This is an averaged value considering the unit as a paralelepipedic box with five exposed face areas.



Controls System

Tracer UC800 Controller

Today's Sintesis™ chillers offer predictive controls that anticipate and compensate for load changes. Other control strategies made possible with the Tracer UC800 controls are:

Soft Loading

The chiller controller uses soft loading except during manual operation. Large adjustments due to load or set-point changes are made gradually, preventing the compressor from cycling unnecessarily. It does this by internally filtering the set-points to avoid reaching the differential-to-stop or the demand limit. Soft loading applies to the leaving chilled-water temperature and demand limit set-points.

Adaptive Controls

There are many objectives that the controller must meet, but it cannot satisfy more than one objective at a time. Typically, the controllers' primary objective is to maintain the evaporator leaving water temperature.

Whenever the controller senses that it can no longer meet its primary objective without triggering a protective shutdown, it focuses on the most critical secondary objective. When the secondary objective is no longer critical, the controller reverts to its primary objective.

Rapid Restart

The controller allows the Sintesis chiller to perform a Rapid Restart. A Rapid Restart is performed after a momentary power loss if it occurs during operation.

Similarly, if the chiller shuts down on a non-latching diagnostic and the diagnostic later clears itself, a Rapid Restart will be initiated.

Variable-Primary Flow (VPF)

Chilled-water systems that vary the water flow through chiller evaporators have caught the attention of engineers, contractors, building owners, and operators. Varying the water flow reduces the energy consumed by pumps, while having limited effect on the chiller energy consumption. This strategy can be a significant source of energy savings, depending on the application.

TD7 Operator Interface

The standard TD7 display provided with the Trane UC800 controller features a 7" LCD touch-screen, allowing access to all operational inputs and outputs. This is an advanced interface that allows the user to access any important information concerning set-points, active temperatures, modes, electrical data, pressure, and diagnostics.

Display Features Include:

- Factory-mounted above the control panel door
- UV Resistant touchscreen
- -40°C to 70°C Operating temperature
- IP56 rated
- CE marking
- Emissions: EN55011(Class B)
- Immunity: EN61000(Industrial)
- 7" diagonal
- 800x480 pixels
- TFT LCD @ 600 nits brightness
- 16 bit color graphic display
- Display features:
 - Alarms
 - Reports
 - Chiller settings
 - Display settings
 - Graphing
 - Support for 15 languages

Figure 9 – TD7 operator interface



System Integration

Stand-Alone Controls

Single chillers installed in applications without a building management system are simple to install and control: only a remote auto/stop for scheduling is required for unit operation. Signals from the chilled-water pump contactor auxiliary, or a flow switch, are wired to the chilled-water flow interlock. Signals from a time clock or some other remote device are wired to the external auto/ stop input.

- Auto/Stop-A job-site provided contact closure turns the unit on and off.
- External Interlock-A job-site provided contact opening wired to this input turns the unit off and requires a manual reset of the unit microcomputer. This closure is typically triggered by a job-site provided system such as a fire alarm.

Hardwire Points

Microcomputer controls allow simple interface with other control systems, such as time clocks, building automation systems, and ice storage systems via hardwire points. This means you have the flexibility to meet job requirements while not having to learn a complicated control system. Remote devices are wired from the control panel to provide auxiliary control to a building automation system. Inputs and outputs can be communicated via a typical 4–20 mA electrical signal, an equivalent 2–10 V dc signal, or by utilizing contact closures. This setup has the same features as a stand-alone water chiller, with the possibility of having additional optional features:

- Ice making control.
- External chilled water set-point, external demand limit set-point.
- Chilled water temperature reset.
- Programmable relays - available outputs are: alarm- latching, alarm-auto reset, general alarm-warning, chiller limit mode, compressor running, and Tracer control.
- **BACnet Interface**
- UC800 control can be configured for BACnet communications at the factory or in the field. This enables the chiller controller to communicate on a BACnet MS/TP network. Chiller set-points, operating modes, alarms, and status can be monitored and controlled through BACnet. Tracer TD7 controls conforms to the BACnet B-ASC profile as defined by ASHRAE 135-2004.
- LonTalk Communications Interface (LCI-C).
- The optional LonTalk® Communications Interface for Chillers (LCI-C) is available factory or field installed. It is an integrated communication board that enables the chiller controller to communicate over a LonTalk network. The LCI-C is capable of controlling and monitoring chiller set-points, operating modes, alarms, and status. The Trane LCI-C provides additional points beyond the standard LONMARK® defined chiller profile to extend interoperability and support a broader range of system applications. These added points are referred to as open extensions. The LCI-C is certified to the LONMARK Chiller Controller Functional Profile 8040 version 1.0, and follows LonTalk FTT-10A free topology communications.
- UC800 Modbus Interface Tracer TD7 control can be configured for Modbus communications at the factory or in the field.
- This enables the chiller controller to communicate as a slave device on a Modbus network. Chiller set-points, operating modes, alarms, and status can be monitored and controlled by a Modbus master device.

Dimensional Data

The dimensional data below are given for reference only. Dimensions details, dimensions of hydraulic connections, electrical connections, weights, isolator positioning, specific features for heat recovery and free cooling are included in submittals and diagrams provided in documentation package.

Figure 10 – Typical submittal example

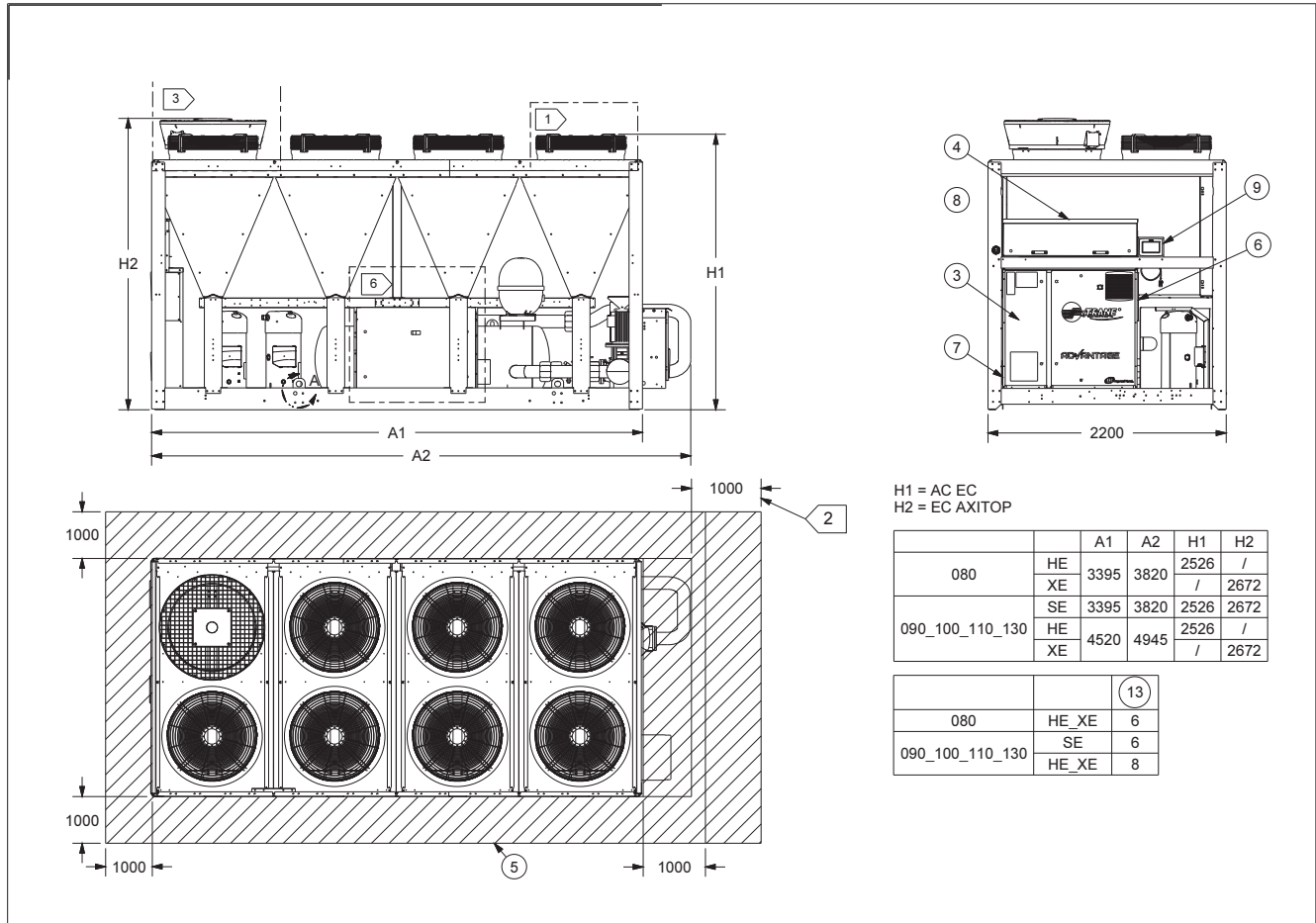

Dimensional Data

Table 7 – CGAF Standard Efficiency (SE) unit dimensions

CGAF SE Dimensions	Size	090	100	110	130	140	150	165	180	190
Unit Length	(mm)	3395	3395	3395	3395	4520	4520	4520	5645	5645
Unit Width	(mm)	2200	2200	2200	2200	2200	2200	2200	2200	2200
Std Unit Height	(mm)	2526	2526	2526	2526	2526	2526	2526	2526	2526
Axitop EC Fan Unit - (Additional height configuration)	(mm)	146	146	146	146	146	146	146	146	146
Pump Package Option - (Additional length configuration)	(mm)	425	425	425	425	370	370	370	370	370

Table 8 – CGAF High Efficiency (HE) and Extra High Efficiency (XE) unit dimensions

CGAF HE/XE Dimensions	Size	080	090	100	110	130	140	150	165	180	190
Unit Length	(mm)	3395	4520	4520	4520	4520	5645	5645	5645	6770	6770
Unit Width	(mm)	2200	2200	2200	2200	2200	2200	2200	2200	2200	2200
Std Unit Height	(mm)	2526	2526	2526	2526	2526	2526	2526	2526	2526	2526
Axitop EC Fan Unit - (Additional height configuration)	(mm)	146	146	146	146	146	146	146	146	146	146
Pump Package Option - (Additional length configuration)	(mm)	425	425	425	425	425	370	370	370	370	370

Table 9 – CGAF unit weights

Weights (1)	Size	080	090	100	110	130	140	150	165	180	190
Shipping Weight - CGAF SE	(kg)		2085	2195	2260	2325	2835	3010	3075	3440	3515
Operating Weight - CGAF SE	(kg)		2145	2260	2330	2400	2915	3100	3175	3550	3630
Shipping Weight - CGAF HE	(kg)	2015	2410	2540	2615	2675	3205	3385	3425	3790	3855
Operating Weight - CGAF HE	(kg)	2085	2480	2615	2700	2770	3315	3500	3540	3910	3975
Shipping Weight - CGAF XE	(kg)	2075	2490	2620	2695	2755	3305	3485	3525	3910	3975
Operating Weight - CGAF XE	(kg)	2145	2560	2695	2780	2850	3415	3600	3640	4030	4095

Option Additional shipping weight - CGAF SE		090	100	110	130	140	150	165	180	190
Single pump - Standard head pressure	(kg)	215	220	225	225	230	230	295	310	305
Single pump - High head pressure	(kg)	260	265	265	260	305	305	305	320	320
Twin pump - Standard head pressure	(kg)	300	305	325	320	325	325	440	450	450
Twin pump - High head pressure	(kg)	385	390	385	385	460	460	465	480	475
Axitop option	(kg)	60	60	60	60	80	80	80	100	100
XLN option	(kg)	115	115	115	115	150	150	150	150	150
Pump VFD option	(kg)	70	70	70	70	70	70	70	70	70
Partial heat recovery option (Digit 19 = N)	(kg)	45	45	65	65	75	75	75	75	75
Partial heat recovery option (Digit 19 = P)	(kg)	45	45	45	45	75	75	75	75	75
Water Buffer tank option	(kg)	250	250	250	250	330	330	330	330	330

Option Additional shipping weight - CGAF HE / XE		080	090	100	110	130	140	150	165	180	190
Single pump - Standard head pressure	(kg)	215	230	225	235	235	245	240	305	330	325
Single pump - High head pressure	(kg)	265	275	270	270	270	320	315	315	340	340
Twin pump - Standard head pressure	(kg)	305	315	315	335	335	345	340	450	475	470
Twin pump - High head pressure	(kg)	385	400	395	395	395	480	475	475	500	495
XLN option	(kg)	115	115	115	115	115	150	150	150	150	150
Pump VFD option	(kg)	70	70	70	70	70	70	70	70	70	70
Partial heat recovery option (Digit 19 = N)	(kg)	45	45	45	65	65	75	75	75	75	75
Partial heat recovery option (Digit 19 = P)	(kg)	45	45	45	45	45	75	75	75	75	75
Water Buffer tank option	(kg)	250	250	250	250	250	330	330	330	330	330

1) Rated Condition without Pump Package

Trane - by Trane Technologies (NYSE: TT), a global climate innovator - creates comfortable, energy efficient indoor environments for commercial and residential applications. For more information, please visit trane.com or tranetechnologies.com.

Trane has a policy of continuous product and product data improvement and reserves the right to change design and specifications without notice. We are committed to using environmentally conscious print practices.

CG-PRC051B-GB August 2020
Supersedes CG-PRC051A-GB (February 2018)

© 2020 Trane

Confidential and proprietary Trane information