



Installation Operation Maintenance

CGAF
Air-cooled Scroll Chillers
260 - 670 kW



SINTECIS™
ADVANTAGE

CG-SVX039A-GB
Original instructions

Table of Contents

Introduction	3
Unit Model Number Description	4
General Data	6
Table 1 – General data CGAF 090-190 standard efficiency	6
Table 2 – General data CGAF 080-190 high efficiency	9
Table 3 – General data CGAF 080-190 extra efficiency	12
Typical Components location	15
Installation Requirements	16
Evaporator Piping	19
Installation - Mechanical	22
Evaporator Waterside	26
General Electrical Recommendations.....	29
Installer-Supplied Components.....	31
Operating principles	32
Operating Map	34
Controls	35
Pre-Start Checkout	36
Unit Start Up Procedures.....	39
Periodic Maintenance	41
Compressor Maintenance.....	43
MCHE Condenser Coils Maintenance	46
Integrated Pump Maintenance	47
Log Check Sheet.....	48
Recommended service routine frequencies.....	49
Additional services	50

Introduction

Foreword

These instructions are given as a guide to good practice in the installation, start-up, operation, and maintenance by the user, of Trane CGAF chillers, manufactured in France. A separate manual is available for the use and maintenance of the unit's control, Tracer™ UC800. They do not contain full service procedures necessary for the continued successful operation of this equipment. The services of a qualified technician should be employed through the medium of a maintenance contract with a reputable service company. Read this manual thoroughly before unit start-up.

Units are assembled, pressure tested, dehydrated, charged and tested in accordance with factory standard before shipment.

Warnings and Cautions

Warnings and Cautions appear at appropriate sections throughout this manual. Your personal safety and the proper operation of this machine require that you follow them carefully. The constructor assumes no liability for installations or servicing performed by unqualified personnel.

WARNING: Indicates a potentially hazardous situation which, if not avoided, could result in death or serious injury.

CAUTION: Indicates a potentially hazardous situation which, if not avoided, may result in minor or moderate injury. It may also be used to alert against unsafe practices or for equipment or property-damage-only accidents.

Safety Recommendations

To avoid death, injury, equipment or property damage, the following recommendations should be observed during maintenance and service visits:

1. The maximum allowable pressures for system leak testing on low and high pressure side are given in the chapter "Installation". Insure to do not exceed test pressure by using appropriate device.
2. Disconnect all power supplies before any servicing on the unit.
3. Service work on the refrigeration system and the electrical system should be carried out only by qualified and experienced personnel.
4. To avoid any risk, it is recommended to place the unit on an area with limited access.

Reception

On arrival, inspect the unit before signing the delivery note. Specify any visible damage on the delivery note, and send a registered letter of protest to the last carrier of the goods within 7 days of delivery.

Notify the local TRANE sales office at the same time.

The delivery note must be clearly signed and countersigned by the driver.

Any concealed damage shall be notified by a registered letter of protest to the last carrier of the goods within 7 days of delivery. Notify the local TRANE sales office at the same time.

Important notice: No shipping claims will be accepted by TRANE if the above mentioned procedure is not respected.

For more information, refer to the general sales conditions of your local TRANE sales office.

Note: Unit inspection in France. Delay to send registered letter in case of visible and concealed damage is only 72 hours.

Loose Parts Inventory

Check all the accessories and loose parts that are shipped with the unit against the shipping list. Included in these items will be the water vessel drain plugs, rigging and electrical diagrams, service literature, which are placed inside the control panel and/or starter panel for shipment. If optional elastomeric isolators are ordered with the unit they are shipped mounted on the horizontal support frame of the chiller. The isolators' location and distribution weight diagram is placed with the service literature inside the starter/control panel.

Warranty

Warranty is based on the general terms and conditions of the manufacturer. The warranty is void if the equipment is repaired or modified without the written approval of the manufacturer, if the operating limits are exceeded or if the control system or the electrical wiring is modified. Damage due to misuse, lack of maintenance or failure to comply with the manufacturer's instructions or recommendations is not covered by the warranty obligation. If the user does not conform to the rules of this manual, it may entail cancellation of warranty and liabilities by the manufacturer.



Unit Model Number Description

Digit 1, 2, 3, 4 – Unit model

CGAF = Air-Cooled Scroll Package Chiller

Digit 5-7 – Unit Nominal Tonnage

080 = 80 Tons
090 = 90 Tons
100 = 100 Tons
110 = 110 Tons
130 = 130 Tons
140 = 140 Tons
150 = 150 Tons
165 = 165 Tons
180 = 180 Tons
190 = 190 Tons

Digit 8 – Unit voltage

D = 400V/50Hz/3ph

Digit 9 – Manufacturing Location

E = Europe

Digit 10, 11 – Design sequence

AA = Factory assigned

Digit 12 – Efficiency

N = Standard Efficiency
H = High Efficiency
A = Extra Efficiency

Digit 13 – Agency listing

C = CE Marking

Digit 14 – Pressure vessel code

2 = PED (Pressure equipment directive)

Digit 15 – Acoustic level

X = Standard noise (SN)
L = Low noise (LN)
E = Extra Low Noise (XLN)

Digit 16 – Unit Application

X = Standard Ambient [-10C ; +46C]
L = Low Ambient [-20C ; +46C]
H = High Ambient [-10C ; +52C]
D = Wide Ambient [-20 ; + 52C]

Digit 17 – Relief valve option

W = Without

Digit 18 – Water connection

X = Grooved pipe connection
W = Grooved pipe + welded coupling
2 = Grooved pipe with coupling and Flange adapter

Digit 19 – Evaporator Application

N = Standard cooling [4C ; 20C]
P = Low Temperature process [-12C ; 4C]
C = Ice Making [-7C ; 20C] with hardwired interface

Digit 20 – Evaporator Configurations

B = Brazed plate heat exchanger

Digit 21 – Thermal Insulation

N = Standard

Digit 22 – Condenser Coating

N = Aluminum Micro Channel
C = E-Coated Micro Channel (Free Cooling excluded)

Digit 23 – Heat Recovery

X = No Heat Recovery
P = Partial Heat Recovery
T = Total Heat Recovery (full equipment)
V = Total Heat Recovery (no piping connection)

Digit 24 – Hydraulic module

X = Pump signal On/Off
1 = Dual pump standard pressure
2 = Single pump standard pressure
3 = Dual pump high pressure
4 = Single pump high pressure

Digit 25 – Free Cooling

X = Without
F = Total Free-Cooling Direct

Digit 26 – Disconnect switch

B = With circuit breaker

Digit 27 – Under/Over Voltage

X = None
1 = Included
2 = Included with ground fault protection

Digit 28 – Human Interface language

C = Spanish
D = German
E = English
F = French
H = Dutch
I = Italian
M = Swedish
P = Polish
R = Russian
T = Czech
U = Greek
V = Portuguese
2 = Romanian
6 = Hungarian
8 = Turkish

Digit 29 – Smart com protocol

X = None
B = Bacnet interface
M = Modbus interface
L = LonTalk interface

Digit 30 – Communication customer

X = None
A = External set point & capacity outputs

Digit 31 – Flow switch

X = None
F = Field installed flow switch

Unit Model Number Description

Digit 32 – Electrical Panel Protection

X = Enclosure with deadfront protection
1 = Enclosure with IP 20 internal protection

Digit 33 – Master Slave

X = Without
A = With

Digit 34 – Unit User Interface

L = Standard, Local UI supplied (TD7)

Digit 35 – Energy meter

X = Without
M = With

Digit 36 – Mini Chiller Plant Control

X = Without

Digit 37 – Variable Primary Flow

X = Constant speed pump (no AFD)
A = Pump flow controlled by 3 ways Duty Valve
F = Constant Speed Pump -AFD Adjustment
T = Variable Speed Pump - Constant delta T

Digit 38 – Open for future use = X

Digit 39 – Open for future use = X

Digit 40 – Power socket

X = None
P = Included (230V - 100W)

Digit 41 – Factory tests

X = No final performances test
B = Visual inspection with customer
E = Performance test without customer

Digit 42 – Installation accessory

X = None
1 = Neoprene Isolators
4 = Neoprene pads

Digit 43 – Literature language

C = Spanish
D = German
E = English
F = French
H = Dutch
I = Italian
M = Swedish
P = Polish
R = Russian
T = Czech
U = Greek
V = Portuguese
2 = Romanian
6 = Hungarian
8 = Turkish

Digit 44 – Shipping package

X = Standard protection
A = Containerization package

Digit 45 – Refrigerant

X = None
A = R410A

Digit 46 – Isolator Valve per Manifold Compressor

X = None

Digit 47 – Open for future use = X

Digit 48 – Open for future use = X

Digit 49 – Freeze Protection (Factory Installed)

X = None
2 = With

Digit 50 – Buffer Tank

X = Without
1 = With

Digit 51 – Water Strainer

X = Without
A = With

Digit 52 – Louvered panels

X = None

Digit 53 – Open for future use = X

Digit 54 – Starter type

A = Across the line starter/Direct On Line
B = Soft starter

Digit 55 – Annuciation Relay

X = None
A = With

Digit 56 – Fan type

1 = AC fan
2 = EC fan
3 = EC with Axitop

Digit 57 – Night Noise Setback (NNSB)

X = Without
1 = With

Digit 58 – Design special

X = Standard
S = Special requirement



General Data

Table 1 – General data CGAF 090-190 Standard Efficiency

		CGAF 90 SE	CGAF 100 SE	CGAF 110 SE	CGAF 130 SE	CGAF 140 SE	CGAF 150 SE	CGAF 165 SE	CGAF 180 SE	CGAF 190 SE
Digit 56=1										
Net Cooling Capacity (1)	(kW)	318	351	391	431	467	519	558	621	661
Total Power input in cooling (1)	(kW)	105	120	138	157	160	183	202	211	230
Digit 56=2										
Net Cooling Capacity (1)	(kW)	321	355	395	437	478	525	566	627	669
Total Power input in cooling (1)	(kW)	102	117	135	153	156	179	197	206	224
Digit 56=3										
Net Cooling Capacity (1)	(kW)	321	355	395	437	478	525	566	628	670
Total Power input in cooling (1)	(kW)	101	116	134	153	155	178	196	205	223
Unit electrical data (2) (3) (4)										
Short Circuit Unit Capacity	(kA)	35	35	35	35	35	35	35	35	35
Power Cable Cross Section (max)	mm ²	1*240	1*240	1*240	1*240	1*240	2*300	2*300	2*300	2*300
Disconnect switch size	(A)	400	400	400	500	500	630	630	630	800
Digit 12=2 or Digit 12=1 and Digit 41=2										
Maximum Power input	(kW)	275.3	310.2	337.9	365.7	405.8	464.5	492.3	521.5	549.2
Unit rated amps	(A)	177.0	202.1	230.4	260.9	269.7	307.9	337.7	354.8	383.9
Unit start up amps (w/o soft starter - Digit 26=A) (4)	(A)	2337.4	2577.4	2949.4	3321.4	3503.2	3863.2	4235.2	4613.0	4985.0
Unit start up amps (with soft starter - Digit 26=B) (4)	(A)	1409.4	1553.4	1776.6	1999.8	2111.2	2327.2	2550.4	2779.4	3002.6
Displacement power factor (dpf)		0.853	0.854	0.864	0.870	0.854	0.859	0.865	0.860	0.864
Digit 12=1 and Digit 15=A										
Maximum Power input	(kW)	278.4	317.5	345.3	373.0	415.6	474.3	502.1	533.8	561.5
Unit rated amps	(A)	170.8	195.4	223.0	252.5	260.6	298.0	327.0	343.0	371.3
Unit start up amps (w/o soft starter - Digit 26=A) (4)	(A)	2338.0	2578.0	2950.0	3322.0	3504.0	3864.0	4236.0	4614.0	4986.0
Unit start up amps (with soft starter - Digit 26=B) (4)	(A)	1427.4	1571.4	1794.6	2017.8	2135.2	2351.2	2574.4	2809.4	3032.6
Power factor		0.863	0.863	0.871	0.877	0.866	0.866	0.871	0.868	0.872
Digit 12=1 and Digit 15=C										
Maximum Power input	(kW)	278.4	317.5	345.3	373.0	415.6	474.3	502.1	533.8	561.5
Unit rated amps	(A)	171.3	195.9	223.4	252.9	261.2	298.5	327.5	343.7	372.0
Unit start up amps (w/o soft starter - Digit 26=A) (4)	(A)	2338.0	2578.0	2950.0	3322.0	3504.0	3864.0	4236.0	4614.0	4986.0
Unit start up amps (with soft starter - Digit 26=B) (4)		1427.4	1571.4	1794.6	2017.8	2135.2	2351.2	2574.4	2809.4	3032.6
Displacement power factor (dpf)		0.854	0.855	0.864	0.871	0.858	0.859	0.865	0.861	0.865
Compressor										
Compressor Number per Circuit	#	2	2	2	2	3	3	3	3	3
Type		Scroll	Scroll	Scroll	Scroll	Scroll	Scroll	Scroll	Scroll	Scroll
Model Circuit1 / Circuit 2		25+30/25+30	30+30/30+30	30+40/30+40	40+40/40+40	30+30+30/ 25+25+25	30+30+30/ 30+30+30	30+30+40/ 30+30+40	30+40+40/ 30+40+40	40+40+40/ 40+40+40
Max Compr Power input Circuit 1 / Circuit 2	kW	28.4+38.2/ 28.4+38.2	38.2+38.2/ 38.2+38.2	38.2+45.2/ 38.2+45.2	45.2+45.2/ 45.2+45.2	38.2+38.2+38.2/ 28.4+28.4+28.4	38.2+38.2+38.2/ 38.2+38.2+38.2	38.2+38.2+45.2/ 38.2+38.2+45.2	38.2+45.2+45.2/ 38.2+45.2+45.2	45.2+45.2+45.2/ 45.2+45.2+45.2
Rated Amps Circuit1 / Circuit 2 (4)	(A)									
Locked Rotor Amps Circuit1 / Circuit 2 (4)	(A)	260+320/ 260+320	320+320/ 320+320	320+413/ 320+413	413+413/ 413+413	320+320+320/ 260+260+260	320+320+320/ 320+320+320	320+320+413/ 320+320+413	320+413+413/ 320+413+413	413+413+413/ 413+413+413
Motor RPM	(rpm)	2900	2900	2900	2900	2900	2900	2900	2900	2900
Oil sump heater Circuit1 / Circuit 2	(W)	112/112	112/112	112/112	112/112	168/168	168/168	168/168	168/168	168/168
Evaporator										
Quantity	#	1	1	1	1	1	1	1	1	1
Type		Stainless steel Copper Brazed plate Heat exchanger								
Evaporator model		DFX650x106	DFX650x122	DFX650x138	DFX650x166	DFX650x166	DFX650x194	DFX650x222	DFX650x250	DFX650x278
Evaporator Water Content volume	(l)	31.0	35.7	40.4	48.6	48.6	56.7	64.9	73.1	81.3
Nominal water connection size (Grooved coupling) - Without HYM	(in) - (mm)	4" - 114.3	4" - 114.3	4" - 114.3	4" - 114.3	5" - 139.7	5" - 139.7	5" - 139.7	5" - 139.7	5" - 139.7
Nominal water connection size (Grooved coupling) - With HYM	(in) - (mm)	4" - 114.3	4" - 114.3	4" - 114.3	4" - 114.3	5" - 139.7	5" - 139.7	5" - 139.7	5" - 139.7	5" - 139.7

General Data

Table 1 – General data CGAF 090-190 Standard Efficiency (continued)

		CGAF 90 SE	CGAF 100 SE	CGAF 110 SE	CGAF 130 SE	CGAF 140 SE	CGAF 150 SE	CGAF 165 SE	CGAF 180 SE	CGAF 190 SE
Hydraulic Module Components										
Single pump - Standard head pressure option										
Max available Head Pressure	(kPa)	123	115	98	92	142	137	124	164	155
Motor Power	(kW)	5.5	5.5	7.5	7.5	7.5	7.5	11.0	11.0	11.0
Rated Amps	(A)	11.0	11.0	14.4	14.4	14.4	14.4	20.8	20.8	20.8
Single pump - High head pressure option										
Max available Head Pressure	(kPa)	251	247	234	232	249	252	245	234	226
Motor Power	(kW)	11.0	11.0	11.0	11.0	15.0	15.0	15.0	15.0	15.0
Rated Amps	(A)	20.8	20.8	20.8	20.8	28.0	28.0	28.0	28.0	28.0
Twin pump - Standard head pressure option										
Max available Head Pressure	(kPa)	123	115	98	92	142	137	124	164	155
Motor Power	(kW)	5.5	5.5	7.5	7.5	7.5	7.5	11.0	11.0	11.0
Rated Amps	(A)	11.0	11.0	14.4	14.4	14.4	14.4	20.8	20.8	20.8
Twin pump - High head pressure option										
Max available Head Pressure	(kPa)	251	247	234	232	249	252	245	234	226
Motor Power	(kW)	11.0	11.0	11.0	11.0	15.0	15.0	15.0	15.0	15.0
Rated Amps	(A)	20.8	20.8	20.8	20.8	28.0	28.0	28.0	28.0	28.0
Expansion Tank Volume	(l)	50	50	50	50	50	50	50	50	50
Max User water loop Volume for factory mounted expansion tank (1)	(l)	1750	1750	1750	1750	1750	1750	1750	1750	1750
Optional water Buffer tank volume	(l)	607	607	607	607	777	777	777	777	777
Antifreeze Heater without pump package and without buffer tank	(W)	360	420	420	420	540	640	640	640	640
Antifreeze Heater with pump package and without buffer tank	(W)	840	900	900	900	1080	1180	1180	1180	1180
Antifreeze Heater with pump package and with buffer tank	(W)	1820	1880	1880	1880	2630	2730	2730	2730	2730
Condenser										
Type		Full aluminum Micro channel heat exchanger								
Quantity of coil	#	6	6	6	6	8	8	8	10	10
Face area per circuit	(m ²)	8.88	8.88	8.88	8.88	11.84	11.84	11.84	14.80	14.80
Condenser Fan										
Quantity	#	6	6	6	6	8	8	8	10	10
Diameter	(mm)	800								
Fan / motor Type		Propeller fan : Fixed speed AC motor / Variable speed EC motor / Variable speed EC motor with Axitop								
Digit 56=1										
Fan / motor Type		Fixed speed AC motor								
Airflow per fan	(m ³ /h)	15859	15778	15680	15580	15686	15684	15609	15730	15670
Max Power Input	(kW)	1.44	1.44	1.44	1.44	1.44	1.44	1.44	1.44	1.44
Max Amps	(A)	2.9	2.9	2.9	2.9	2.9	2.9	2.9	2.9	2.9
Motor RPM	(rpm)	900	900	900	900	900	900	900	900	900
Digit 56=2										
Fan / motor Type		Variable speed EC motor								
Airflow per fan	(m ³ /h)	17295	17215	17120	17021	17125	17124	17050	17168	17109
Max Power Input	(kW)	1.95	1.95	1.95	1.95	1.95	1.95	1.95	1.95	1.95
Max Amps	(A)	3.0	3.0	3.0	3.0	3.0	3.0	3.0	3.0	3.0
Motor RPM	(rpm)	840	840	840	840	840	840	840	840	840
Digit 56=3										
Fan / motor Type		Variable speed EC motor with Axitop								
Airflow per fan	(m ³ /h)	17411	17331	17235	17136	17240	17239	17165	17283	17225
Max Power Input	(kW)	1.95	1.95	1.95	1.95	1.95	1.95	1.95	1.95	1.95
Max Amps	(A)	3.0	3.0	3.0	3.0	3.0	3.0	3.0	3.0	3.0
Motor RPM	(rpm)	800	840	840	840	840	840	840	840	840

General Data

Table 1 – General data CGAF 090-190 Standard Efficiency (continued)

		CGAF 90 SE	CGAF 100 SE	CGAF 110 SE	CGAF 130 SE	CGAF 140 SE	CGAF 150 SE	CGAF 165 SE	CGAF 180 SE	CGAF 190 SE
Partial Heat recovery (PHR) option										
Heat-Exchanger Type		Stainless steel Copper Brazed plate Heat exchanger								
Digit 19=N or C										
Heat-Exchanger Model		B12MT/D-80	B12MT/D-80	B35TM4/D-48	B35TM4/D-48	B35TM4/D-64	B35TM4/D-64	B35TM4/D-64	B35TM4/D-64	B35TM4/D-64
Water connection size (Thread connection)	(in) - (mm)	2" - 60.3	2" - 60.3	2" - 60.3	2" - 60.3	2 1/2" - 76.1	2 1/2" - 76.1	2 1/2" - 76.1	2 1/2" - 76.1	2 1/2" - 76.1
Water content volume	(l)	2.40	2.40	4.32	4.32	5.76	5.76	5.76	5.76	5.76
Digit 19=P										
Heat-Exchanger Model		B12MT/D-48	B12MT/D-48	B12MT/D-48	B12MT/D-60	B35TM4/D-48	B35TM4/D-48	B35TM4/D-48	B35TM4/D-64	B35TM4/D-64
Water connection size (Thread connection)	(in) - (mm)	1 1/2" - 48.3	1 1/2" - 48.3	1 1/2" - 48.3	2" - 60.3	2" - 60.3	2" - 60.3	2" - 60.3	2 1/2" - 76.1	2 1/2" - 76.1
Water content volume	(l)	1.44	1.44	1.44	1.80	4.32	4.32	4.32	5.76	5.76
Dimensions										
Unit Length	(mm)	3395	3395	3395	3395	4520	4520	4520	5645	5645
Unit Width	(mm)	2200	2200	2200	2200	2200	2200	2200	2200	2200
Std Unit Height	(mm)	2526	2526	2526	2526	2526	2526	2526	2526	2526
Axitop EC Fan Unit - (Additional height configuration)	(mm)	+146	+146	+146	+146	+146	+146	+146	+146	+146
Pump Package Option - (Additional length configuration)	(mm)	+425	+425	+425	+425	+370	+370	+370	+370	+370
Weights										
Shipping Weight (3)	(kg)	2085	2195	2260	2325	2835	3010	3075	3440	3515
Operating Weight (3)	(kg)	2145	2260	2330	2400	2915	3100	3175	3550	3630
Option Additional shipping weight										
Single pump - Standard head pressure	(kg)	215	220	225	225	230	230	295	310	305
Single pump - High head pressure	(kg)	260	265	265	260	305	305	305	320	320
Twin pump - Standard head pressure	(kg)	300	305	325	320	325	325	440	450	450
Twin pump - High head pressure	(kg)	385	390	385	385	460	460	465	480	475
Axitop option	(kg)	60	60	60	60	80	80	80	100	100
XLN option	(kg)	115	115	115	115	150	150	150	150	150
Pump VFD option	(kg)	70	70	70	70	70	70	70	70	70
Partial heat recovery option	(kg)									
Water Buffer tank option	(kg)	250	250	250	250	330	330	330	330	330
System data										
Nb of refrigerant circuit	#	2	2	2	2	2	2	2	2	2
Minimum cooling load %	%	23	25	21	25	15	17	15	14	17
Standard/Partial Heat Recovery Unit										
R410A refrigerant charge Circuit1 / Circuit 2	(kg)	18.2 / 18.2	19.0 / 19.0	19.5 / 19.5	20.7 / 20.7	30.3 / 30.3	31.7 31.7	32.9 / 32.9	37.7 / 37.7	39.0 / 38.0
Oil charge Circuit1 / Circuit 2	(l)	12.8 / 12.8	12.8 / 12.8	12.8 / 12.8	12.8 / 12.8	23.1 / 22.1	23.1 / 23.1	23.1 / 23.1	23.1 / 23.1	23.1 / 23.1
POE Oil type		OIL058E / OIL057E								

(1) Indicative performance at Evaporator water temperature : 12°C / 7°C - Condenser air temperature 35°C - for detailed performances, on a given unit, consult Order Write Up.

(2) Under 400V/3/50Hz.

(3) Rated Condition without Pump Package.

(4) Electrical & system data are indicative and subject to change without notice. Please refer to unit nameplate data.

(5) If the power line of the unit is protected by fuses gG of the same size as the disconnect switch.

General Data

Table 2 – General data CGAF 080-190 High Efficiency

		CGAF 80 HE	CGAF 90 HE	CGAF 100 HE	CGAF 110 HE	CGAF 130 HE	CGAF 140 HE	CGAF 150 HE	CGAF 165 HE	CGAF 180 HE	CGAF 190 HE
Digit 56=1											
Net Cooling Capacity (1)	(kW)	293	334	371	416	459	495	547	587	641	682
Total Power input in cooling (1)	(kW)	90	102	115	132	149	155	176	193	205	222
Digit 56=2											
Net Cooling Capacity (1)	(kW)	295	333	373	419	463	502	552	592	646	688
Total Power input in cooling (1)	(kW)	88	99	113	129	145	151	172	189	200	217
Unit electrical data (2) (3) (4)											
Short Circuit Unit Capacity (9)	(kA)	35	35	35	35	35	35	35	35	35	35
Power Cable Cross Section (max)	(mm ²)	1*240	1*240	1*240	1*240	1*240	1*240	2*300	2*300	2*300	2*300
Disconnect switch size	(A)	315	400	400	400	500	500	630	630	630	800
Digit 56=1											
Maximum Power input	(kW)	231.9	272.5	311.6	339.3	367.1	407.2	465.9	493.7	522.9	550.7
Unit rated amps	(A)	153.6	175.7	198.6	223.9	250.6	265.4	300.9	327.6	348.0	374.6
Unit start up amps (w/o soft starter - Digit 54=A) (4)	(A)	2097.4	2343.2	2583.2	2955.2	3327.2	3509.0	3869.0	4241.0	4618.8	4990.8
Unit start up amps (with soft starter - Digit 54=B) (4)		1265.4	1415.2	1559.2	1782.4	2005.6	2117.0	2333.0	2556.2	2785.2	3008.4
Displacement power factor (dpf)		0.752	0.739	0.727	0.709	0.749	0.761	0.719	0.727	0.746	0.732
Digit 56=2											
Maximum Power input	(kW)	239.3	282.3	321.4	349.2	376.9	419.5	478.2	506.0	537.7	565.4
Unit rated amps	(A)	147.9	168.8	191.3	215.9	241.9	255.7	290.6	316.5	335.7	361.6
Unit start up amps (w/o soft starter - Digit 54=A) (4)	(A)	2098.0	2344.0	2584.0	2956.0	3328.0	3510.0	3870.0	4242.0	4620.0	4992.0
Unit start up amps (with soft starter - Digit 54=B) (4)		1283.4	1439.2	1583.2	1806.4	2029.6	2147.0	2363.0	2586.2	2821.2	3044.4
Power factor		0.858	0.843	0.851	0.859	0.866	0.854	0.855	0.861	0.862	0.866
Compressor											
Compressor Number per Circuit	#	2	2	2	2	2	3	3	3	3	3
Type		Scroll	Scroll	Scroll	Scroll	Scroll	Scroll	Scroll	Scroll	Scroll	Scroll
Model Circuit 1 / Circuit 2		25+25/ 25+25	25+30/ 25+30	30+30/ 30+30	30+40/ 30+40	40+40/ 40+40	30+30+30/ 25+25+25	30+30+30/ 30+30+30	30+30+40/ 30+30+40	30+40+40/ 30+40+40	40+40+40/ 40+40+40
Max Compr Power input Circuit 1 / Circuit 2	(kW)	28.4+28.4/ 28.4+28.4	28.4+38.2/ 28.4+38.2	38.2+38.2/ 38.2+38.2	38.2+45.2/ 38.2+45.2	45.2+45.2/ 45.2+45.2	38.2+38.2+38.2/ 28.4+28.4+28.4	38.2+38.2+38.2/ 38.2+38.2+38.2	38.2+38.2+45.2/ 38.2+38.2+45.2	38.2+45.2+45.2/ 38.2+45.2+45.2	45.2+45.2+45.2/ 45.2+45.2+45.2
Rated Amps Circuit 1 / Circuit 2 (4)	(A)	260+260/ 260+260	260+320/ 260+320	320+320/ 320+320	320+413/ 320+413	413+413/ 413+413	320+320+320/ 260+260+260	320+320+320/ 320+320+320	320+320+413/ 320+320+413	320+413+413/ 320+413+413	413+413+413/ 413+413+413
Locked Rotor Amps Circuit1 / Circuit 2 (4)	(A)	260+260/ 260+260	260+320/ 260+320	320+320/ 320+320	320+413/ 320+413	413+413/ 413+413	320+320+320/ 260+260+260	320+320+320/ 320+320+320	320+320+413/ 320+320+413	320+413+413/ 320+413+413	413+413+413/ 413+413+413
Motor RPM	(rpm)	2900	2900	2900	2900	2900	2900	2900	2900	2900	2900
Oil sump heater Circuit 1 / Circuit 2	(W)	112/112	112/112	112/112	112/112	112/112	168/168	168/168	168/168	168/168	168/168
Evaporator											
Quantity	#	1	1	1	1	1	1	1	1	1	1
Type		Stainless steel Copper Brazed plate Heat exchanger									
Evaporator model		DFX650x138	DFX650x138	DFX650x166	DFX650x194	DFX650x222	DFX650x250	DFX650x278	DFX650x278	DFX650x78	DFX650x294
Evaporator Water Content volume	(l)	40.4	40.4	48.6	56.7	64.9	73.1	81.3	81.3	81.3	86.0
Nominal water connection size (Grooved coupling) - Without HYM	(in) - (mm)	4" - 114.3	4" - 114.3	4" - 114.3	4" - 114.3	4" - 114.3	5" - 139.7	5" - 139.7	5" - 139.7	5" - 139.7	5" - 139.7
Nominal water connection size (Grooved coupling) - With HYM	(in) - (mm)	4" - 114.3	4" - 114.3	4" - 114.3	4" - 114.3	4" - 114.3	5" - 139.7	5" - 139.7	5" - 139.7	5" - 139.7	5" - 139.7
Hydraulic Module Components											
Single pump - Standard head pressure option											
Max available Head Pressure	(kPa)	155	136	119	103	92	146	134	122	161	149
Motor Power	(kW)	5.5	5.5	5.5	7.5	7.5	7.5	7.5	11.0	11.0	11.0
Rated Amps	(A)	11.0	11.0	11.0	14.4	14.4	14.4	14.4	20.8	20.8	20.8
Single pump - High head pressure option											
Max available Head Pressure	(kPa)	280	266	254	242	237	257	253	249	231	220
Motor Power	(kW)	11.0	11.0	11.0	11.0	11.0	15.0	15.0	15.0	15.0	15.0
Rated Amps	(A)	20.8	20.8	20.8	20.8	20.8	28.0	28.0	28.0	28.0	28.0
Twin pump - Standard head pressure option											
Max available Head Pressure	(kPa)	155	136	119	103	92	146	134	122	161	149
Motor Power	(kW)	5.5	5.5	5.5	7.5	7.5	7.5	7.5	11.0	11.0	11.0
Rated Amps	(A)	11.0	11.0	11.0	14.4	14.4	14.4	14.4	20.8	20.8	20.8



General Data

Table 2 – General data CGAF 080-190 High Efficiency (continued)

		CGAF 80 HE	CGAF 90 HE	CGAF 100 HE	CGAF 110 HE	CGAF 130 HE	CGAF 140 HE	CGAF 150 HE	CGAF 165 HE	CGAF 180 HE	CGAF 190 HE
Twin pump - High head pressure option											
Max available Head Pressure	(kPa)	280	266	254	242	237	257	253	249	231	220
Motor Power	(kW)	11.0	11.0	11.0	11.0	11.0	15.0	15.0	15.0	15.0	15.0
Rated Amps	(A)	20.8	20.8	20.8	20.8	20.8	28.0	28.0	28.0	28.0	28.0
Expansion Tank Volume	(l)	50	50	50	50	50	50	50	50	50	50
Max User water loop Volume for factory mounted expansion tank (1)	(l)	1750	1750	1750	1750	1750	1750	1750	1750	1750	1750
Optional water Buffer tank volume	(l)	607	607	607	607	607	777	777	777	777	777
Antifreeze Heater without pump package and without buffer tank	(W)	420	420	420	520	520	640	640	640	640	640
Antifreeze Heater with pump package and without buffer tank	(W)	900	900	900	1000	1000	1180	1180	1180	1180	1180
Antifreeze Heater with pump package and with buffer tank	(W)	1880	1880	1880	1980	1980	2730	2730	2730	2730	2730
Condenser											
Type		Full aluminum Micro channel heat exchanger									
Quantity of coil	#	6	8	8	8	8	10	10	10	12	12
Face area per circuit	(m ²)	8.88	11.84	11.84	11.84	11.84	14.80	14.80	14.80	17.76	17.76
Condenser Fan											
Quantity	#	6	8	8	8	8	10	10	10	12	12
Diameter	(mm)	800									
Fan / motor Type		Propeller fan : Fixed speed AC motor / Variable speed EC motor									
Digit 56=1											
Fan / motor Type		Fixed speed AC motor									
Airflow per fan	(m ³ /h)	15925	16020	15956	15879	15803	15840	15839	15782	15858	15809
Max Power Input	(kW)	1.44	1.44	1.44	1.44	1.44	1.44	1.44	1.44	1.44	1.44
Max Amps	(A)	2.9	2.9	2.9	2.9	2.9	2.9	2.9	2.9	2.9	2.9
Motor RPM	(rpm)	900	900	900	900	900	900	900	900	900	900
Digit 56=2											
Fan / motor Type		Variable speed EC motor									
Airflow per fan	(m ³ /h)	17360	17453	17390	17315	17240	17276	17276	17220	17294	17246
Max Power Input	(kW)	1.95	1.95	1.95	1.95	1.95	1.95	1.95	1.95	1.95	1.95
Max Amps	(A)	3	3	3	3	3	3	3	3	3	3
Motor RPM	(rpm)	840	840	840	840	840	840	840	840	840	840
Partial Heat recovery (PHR) option											
Heat-Exchanger Type		Stainless steel Copper Brazed plate Heat exchanger									
Digit 19=N or C											
Heat-Exchanger Model		B12MT/D-60	B12MT/D-80	B12MT/D-80	B35TM4/D-48	B35TM4/D-48	B35TM4/D-64	B35TM4/D-64	B35TM4/D-64	B35TM4/D-64	B35TM4/D-64
Water connection size (Thread connection)	(in) - (mm)	1"1/2 - 48.3	2" - 60.3	2" - 60.3	2" - 60.3	2" - 60.3	2"1/2 - 76.1	2"1/2 - 76.1	2"1/2 - 76.1	2"1/2 - 76.1	2"1/2 - 76.1
Water content volume	(l)	1.80	2.40	2.40	4.32	4.32	5.76	5.76	5.76	5.76	5.76
Digit 19=P											
Heat-Exchanger Model		B12MT/D-48	B12MT/D-48	B12MT/D-48	B12MT/D-48	B12MT/D-60	B35TM4/D-48	B35TM4/D-48	B35TM4/D-48	B35TM4/D-64	B35TM4/D-64
Water connection size (Thread connection)	(in) - (mm)	1"1/2 - 48.3	1"1/2 - 48.3	1"1/2 - 48.3	1"1/2 - 48.3	2" - 60.3	2" - 60.3	2" - 60.3	2" - 60.3	2"1/2 - 76.1	2"1/2 - 76.1
Water content volume	(l)	1.44	1.44	1.44	1.44	1.80	4.32 €	4.32 €	4.32 €	5.76 €	5.76 €
Dimensions											
Unit Length	(mm)	3395	4520	4520	4520	4520	5645	5645	5645	6770	6770
Unit Width	(mm)	2200	2200	2200	2200	2200	2200	2200	2200	2200	2200
Std Unit Height	(mm)	2526	2526	2526	2526	2526	2526	2526	2526	2526	2526
Axitop EC Fan Unit - (Additional height configuration)	(mm)	+146	+146	+146	+146	+146	+146	+146	+146	+146	+146
Pump Package Option - (Additional length configuration)	(mm)	+425	+425	+425	+425	+425	+370	+370	+370	+370	+370

General Data

Table 2 – General data CGAF 080-190 High Efficiency (continued)

		CGAF 80 HE	CGAF 90 HE	CGAF 100 HE	CGAF 110 HE	CGAF 130 HE	CGAF 140 HE	CGAF 150 HE	CGAF 165 HE	CGAF 180 HE	CGAF 190 HE
Weights											
Shipping Weight (3)	(kg)	2015	2410	2540	2615	2675	3205	3385	3425	3790	3855
Operating Weight (3)	(kg)	2085	2480	2615	2700	2770	3315	3500	3540	3910	3975
Option Additional shipping weight											
Single pump - Standard head pressure	(kg)	215	230	225	235	235	245	240	305	330	325
Single pump - High head pressure	(kg)	265	275	270	270	270	320	315	315	340	340
Twin pump - Standard head pressure	(kg)	305	315	315	335	335	345	340	450	475	470
Twin pump - High head pressure	(kg)	385	400	395	395	395	480	475	475	500	495
XLN option	(kg)	115	115	115	115	115	150	150	150	150	150
Pump VFD option	(kg)	70	70	70	70	70	70	70	70	70	70
Partial heat recovery option	(kg)										
Water Buffer tank option	(kg)	250	250	250	250	250	330	330	330	330	330
System data											
Nb of refrigerant circuit	#	2	2	2	2	2	2	2	2	2	2
Minimum cooling load %	%	25	23	25	21	25	15	17	15	14	17
Standard/Partial Heat Recovery Unit											
R410A refrigerant charge Circuit 1 / Circuit 2	(kg)	22.0 / 22.0	27.5 / 27.5	27.6 / 27.6	28.3 / 28.3	29.2 / 29.2	39.0 / 39.0	39.0 / 39.0	39.0 / 39.0	42.9 / 42.9	43.4 / 43.4
Oil charge Circuit 1 / Circuit 2	(l)	12.8 / 12.8	12.8 / 12.8	12.8 / 12.8	12.8 / 12.8	12.8 / 12.8	23.1 / 22.1	23.1 / 23.1	23.1 / 23.1	23.1 / 23.1	23.1 / 23.1
POE Oil type		OIL058E / OIL057E									

- (1) Indicative performance at Evaporator water temperature : 12°C / 7°C - Condenser air temperature 35°C - for detailed performances, on a given unit, consult Order Write Up.
- (2) Under 400V/3/50Hz.
- (3) Rated Condition without Pump Package.
- (4) Electrical & system data are indicative and subject to change without notice. Please refer to unit nameplate data.
- (5) If the power line of the unit is protected by fuses gG of the same size as the disconnect switch.



General Data

Table 3 – General data CGAF 080-190 Extra Efficiency

		CGAF 80 XE	CGAF 90 XE	CGAF 100 XE	CGAF 110 XE	CGAF 130 XE	CGAF 140 XE	CGAF 150 XE	CGAF 165 XE	CGAF 180 XE	CGAF 190 XE
Net Cooling Capacity (1)	(kW)	295	334	373	419	464	502	553	593	646	689
Total Power input in cooling (1)	(kW)	87	98	112	128	144	150	171	188	199	216
Unit electrical data (2) (3) (4)											
Short Circuit Unit Capacity	(kA)	35	35	35	35	35	35	35	35	35	35
Power Cable Cross Section (max)	(mm ²)	1*240	1*240	1*240	1*240	1*240	1*240	2*300	2*300	2*300	2*300
Disconnect switch size	(A)	315	400	400	400	500	500	630	630	630	800
Maximum Power input	(kW)	239.3	282.3	321.4	349.2	376.9	419.5	478.2	506.0	537.7	565.4
Unit rated amps	(A)	148.4	169.6	192.0	216.5	242.5	256.6	291.4	317.2	336.7	362.6
Unit start up amps (w/o soft starter - Digit 54=A) (4)	(A)	2098.0	2344.0	2584.0	2956.0	3328.0	3510.0	3870.0	4242.0	4620.0	4992.0
Unit start up amps (with soft starter - Digit 54=B) (4)		1283.4	1439.2	1583.2	1806.4	2029.6	2147.0	2363.0	2586.2	2821.2	3044.4
Displacement power factor (dpf)		0.848	0.836	0.840	0.850	0.858	0.844	0.846	0.853	0.853	0.858
Compressor											
Compressor Number per Circuit	#	2	2	2	2	2	3	3	3	3	3
Type		Scroll	Scroll	Scroll	Scroll	Scroll	Scroll	Scroll	Scroll	Scroll	Scroll
Model Circuit 1 / Circuit 2		25+25/ 25+25	25+30/ 25+30	30+30/ 30+30	30+40/ 30+40	40+40/ 40+40	30+30+30/ 25+25+25	30+30+30/ 30+30+30	30+30+40/ 30+30+40	30+40+40/ 30+40+40	40+40+40/ 40+40+40
Max Compr Power input Circuit 1 / Circuit 2	(kW)	28.4+28.4/ 28.4+28.4	28.4+38.2/ 28.4+38.2	38.2+38.2/ 38.2+38.2	38.2+45.2/ 38.2+45.2	45.2+45.2/ 45.2+45.2	38.2+38.2+38.2/ 28.4+28.4+28.4	38.2+38.2+38.2/ 38.2+38.2+38.2	38.2+38.2+45.2/ 38.2+38.2+45.2	38.2+45.2+45.2/ 38.2+45.2+45.2	45.2+45.2+45.2/ 45.2+45.2+45.2
Rated Amps Circuit 1 / Circuit 2 (4)	(A)										
Locked Rotor Amps Circuit 1 / Circuit 2 (4)	(A)	260+260/ 260+260	260+320/ 260+320	320+320/ 320+320	320+413/ 320+413	413+413/ 413+413	320+320+320/ 260+260+260	320+320+320/ 320+320+320	320+320+413/ 320+320+413	320+413+413/ 320+413+413	413+413+413/ 413+413+413
Motor RPM	(rpm)	2900	2900	2900	2900	2900	2900	2900	2900	2900	2900
Oil sump heater Circuit 1 / Circuit 2	(W)	112/112	112/112	112/112	112/112	112/112	168/168	168/168	168/168	168/168	168/168
Evaporator											
Quantity	#	1	1	1	1	1	1	1	1	1	1
Type		Stainless steel Copper Brazed plate Heat exchanger									
Evaporator model		DFX650x138 DFX650x138 DFX650x166 DFX650x194 DFX650x222 DFX650x250 DFX650x278 DFX650x278 DFX650x278 DFX650x278 DFX650x294									
Evaporator Water Content volume	(l)	40.4	40.4	48.6	56.7	64.9	73.1	81.3	81.3	81.3	86.0
Nominal water connection size (Grooved coupling) - Without HYM	(in) - (mm)	4" - 114.3	4" - 114.3	4" - 114.3	4" - 114.3	4" - 114.3	5" - 139.7	5" - 139.7	5" - 139.7	5" - 139.7	5" - 139.7
Nominal water connection size (Grooved coupling) - With HYM	(in) - (mm)	4" - 114.3	4" - 114.3	4" - 114.3	4" - 114.3	4" - 114.3	5" - 139.7	5" - 139.7	5" - 139.7	5" - 139.7	5" - 139.7
Hydraulic Module Components											
Single pump - Standard head pressure option											
Max available Head Pressure	(kPa)	155	136	119	102	87	141	137	115	159	146
Motor Power	(kW)	5.5	5.5	5.5	7.5	7.5	7.5	7.5	11.0	11.0	11.0
Rated Amps	(A)	11.0	11.0	11.0	14.4	14.4	14.4	14.4	20.8	20.8	20.8
Single pump - High head pressure option											
Max available Head Pressure	(kPa)	280	266	254	241	232	252	257	245	229	218
Motor Power	(kW)	11.0	11.0	11.0	11.0	11.0	15.0	15.0	15.0	15.0	15.0
Rated Amps	(A)	20.8	20.8	20.8	20.8	20.8	28.0	28.0	28.0	28.0	28.0
Twin pump - Standard head pressure option											
Max available Head Pressure	(kPa)	155	136	119	102	87	141	137	115	159	146
Motor Power	(kW)	5.5	5.5	5.5	7.5	7.5	7.5	7.5	11.0	11.0	11.0
Rated Amps	(A)	11.0	11.0	11.0	14.4	14.4	14.4	14.4	20.8	20.8	20.8
Twin pump - High head pressure option											
Max available Head Pressure	(kPa)	280	266	254	241	232	252	257	245	229	218
Motor Power	(kW)	11.0	11.0	11.0	11.0	11.0	15.0	15.0	15.0	15.0	15.0
Rated Amps	(A)	20.8	20.8	20.8	20.8	20.8	28.0	28.0	28.0	28.0	28.0
Expansion Tank Volume	(l)	50	50	50	50	50	50	50	50	50	50
Max User water loop Volume for factory mounted expansion tank (1)	(l)	1750	1750	1750	1750	1750	1750	1750	1750	1750	1750
Optional water Buffer tank volume	(l)	607	607	607	607	607	777	777	777	777	777
Antifreeze Heater without pump package and without buffer tank	(W)	420	420	420	520	520	640	640	640	640	640
Antifreeze Heater with pump package and without buffer tank	(W)	900	900	900	1000	1000	1180	1180	1180	1180	1180
Antifreeze Heater with pump package and with buffer tank	(W)	1880	1880	1880	1980	1980	2730	2730	2730	2730	2730

General Data

Table 3 – General data CGAF 080-190 Extra Efficiency (continued)

		CGAF 80 XE	CGAF 90 XE	CGAF 100 XE	CGAF 110 XE	CGAF 130 XE	CGAF 140 XE	CGAF 150 XE	CGAF 165 XE	CGAF 180 XE	CGAF 190 XE
Condenser											
Type		Full aluminum Micro channel heat exchanger									
Quantity of coil	#	6	8	8	8	8	10	10	10	12	12
Face area per circuit	(m ²)	8.88	11.84	11.84	11.84	11.84	14.80	14.80	14.80	17.76	17.76
Condenser Fan											
Quantity	#	6	8	8	8	8	10	10	10	12	12
Diameter	(mm)	800									
Fan / motor Type		Propeller fan : Variable speed EC motor with Axitop									
Airflow per fan	(m ³ /h)	17476	17569	17506	17430	17355	17392	17391	17335	17410	17362
Max Power Input	(kW)	1.95	1.95	1.95	1.95	1.95	1.95	1.95	1.95	1.95	1.95
Max Amps	(A)	3	3	3	3	3	3	3	3	3	3
Motor RPM	(rpm)	800	800	800	800	800	800	800	800	800	800
Partial Heat recovery (PHR) option											
Heat-Exchanger Type		Stainless steel Copper Brazed plate Heat exchanger									
Digit 19=N or C											
Heat-Exchanger Model		B12MT/D-60	B12MT/D-80	B12MT/D-80	B35TM4/D-48	B35TM4/D-48	B35TM4/D-64	B35TM4/D-64	B35TM4/D-64	B35TM4/D-64	B35TM4/D-64
Water connection size (Thread connection)	(in) - (mm)	1"1/2 - 48.3	2" - 60.3	2" - 60.3	2" - 60.3	2" - 60.3	2"1/2 - 76.1	2"1/2 - 76.1	2"1/2 - 76.1	2"1/2 - 76.1	2"1/2 - 76.1
Water content volume	(l)	1.80	2.40	2.40	4.32	4.32	5.76	5.76	5.76	5.76	5.76
Digit 19=P											
Heat-Exchanger Model		B12MT/D-48	B12MT/D-48	B12MT/D-48	B12MT/D-48	B12MT/D-60	B35TM4/D-48	B35TM4/D-48	B35TM4/D-48	B35TM4/D-64	B35TM4/D-64
Water connection size (Thread connection)	(in) - (mm)	1"1/2 - 48.3	1"1/2 - 48.3	1"1/2 - 48.3	1"1/2 - 48.3	2" - 60.3	2" - 60.3	2" - 60.3	2" - 60.3	2"1/2 - 76.1	2"1/2 - 76.1
Water content volume	(l)	1.44	1.44	1.44	1.44	1.80	4.32 €	4.32 €	4.32 €	5.76 €	5.76 €
Dimensions											
Unit Length	(mm)	3395	4520	4520	4520	4520	5645	5645	5645	6770	6770
Unit Width	(mm)	2200	2200	2200	2200	2200	2200	2200	2200	2200	2200
Std Unit Height	(mm)	2526	2526	2526	2526	2526	2526	2526	2526	2526	2526
Axitop EC Fan Unit - (Additional height configuration)	(mm)	+146	+146	+146	+146	+146	+146	+146	+146	+146	+146
Pump Package Option - (Additional length configuration)	(mm)	+425	+425	+425	+425	+425	+370	+370	+370	+370	+370
Weights											
Shipping Weight (3)	(kg)	2075	2490	2620	2695	2755	3305	3485	3525	3910	3975
Operating Weight (3)	(kg)	2145	2560	2695	2780	2850	3415	3600	3640	4030	4095
Option Additional shipping weight											
Single pump - Standard head pressure	(kg)	215	230	225	235	235	245	240	305	330	325
Single pump - High head pressure	(kg)	265	275	270	270	270	320	315	315	340	340
Twin pump - Standard head pressure	(kg)	305	315	315	335	335	345	340	450	475	470
Twin pump - High head pressure	(kg)	385	400	395	395	395	480	475	475	500	495
XLN option	(kg)	115	115	115	115	115	150	150	150	150	150
Pump VFD option	(kg)	70	70	70	70	70	70	70	70	70	70
Partial heat recovery option	(kg)										
Water Buffer tank option	(kg)	250	250	250	250	250	330	330	330	330	330

General Data

Table 3 – General data CGAF 080-190 Extra Efficiency (continued)

		CGAF 80 XE	CGAF 90 XE	CGAF 100 XE	CGAF 110 XE	CGAF 130 XE	CGAF 140 XE	CGAF 150 XE	CGAF 165 XE	CGAF 180 XE	CGAF 190 XE
System data											
Nb of refrigerant circuit	#	2	2	2	2	2	2	2	2	2	2
Minimum cooling load %	%	25	23	25	21	25	15	17	15	14	17
Standard/Partial Heat Recovery Unit											
R410A refrigerant charge Circuit 1 / Circuit 2	(kg)	22.0 / 22.0	27.4 / 27.4	27.6 / 27.6	28.4 / 28.4	29.4 / 29.4	39.0 / 39.0	39.0 / 39.0	39.0 / 39.0	43.0 / 43.0	43.5 / 43.5
Oil charge Circuit 1 / Circuit 2	(l)	12.8 / 12.8	12.8 / 12.8	12.8 / 12.8	12.8 / 12.8	12.8 / 12.8	23.1 / 22.1	23.1 / 23.1	23.1 / 23.1	23.1 / 23.1	23.1 / 23.1
POE Oil type		OIL058E / OIL057E									

(1) Indicative performance at Evaporator water temperature : 12°C / 7°C - Condenser air temperature 35°C - for detailed performances, on a given unit, consult Order Write Up.

(2) Under 400V/3/50Hz.

(3) Rated Condition without Pump Package.

(4) Electrical & system data are indicative and subject to change without notice. Please refer to unit nameplate data.

(5) If the power line of the unit is protected by fuses gG of the same size as the disconnect switch.

Typical Components location

Figure 1 - Components location

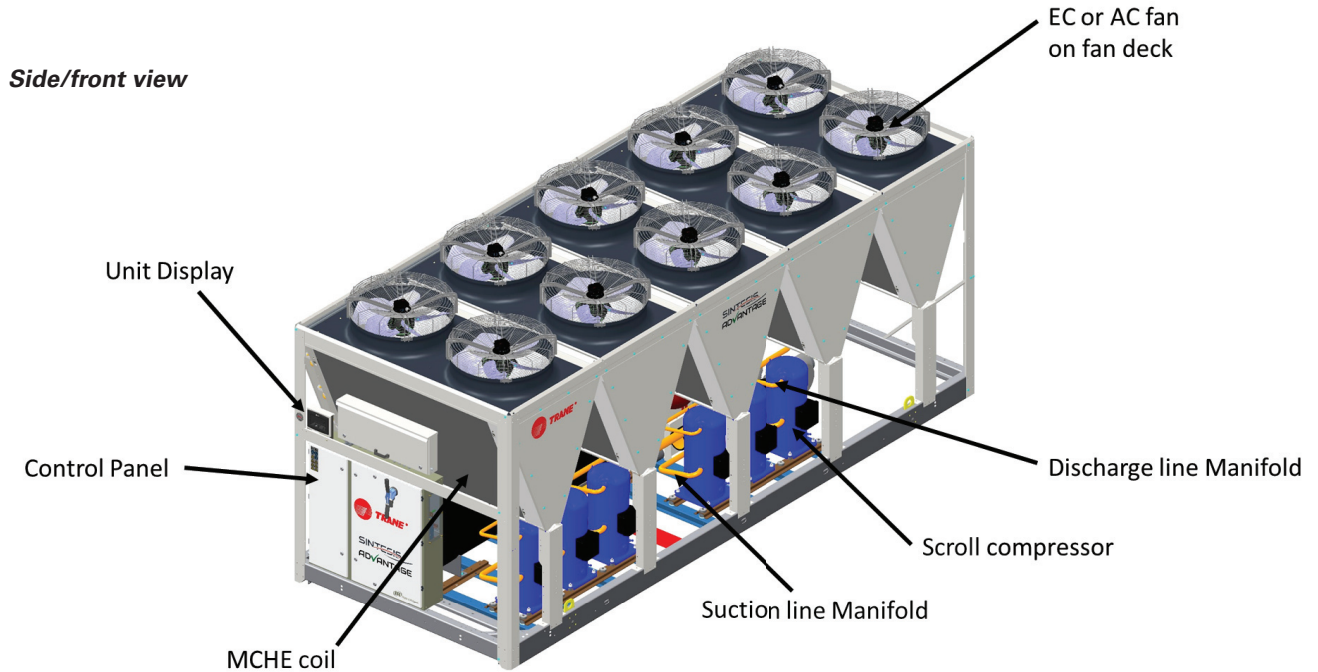

Top view

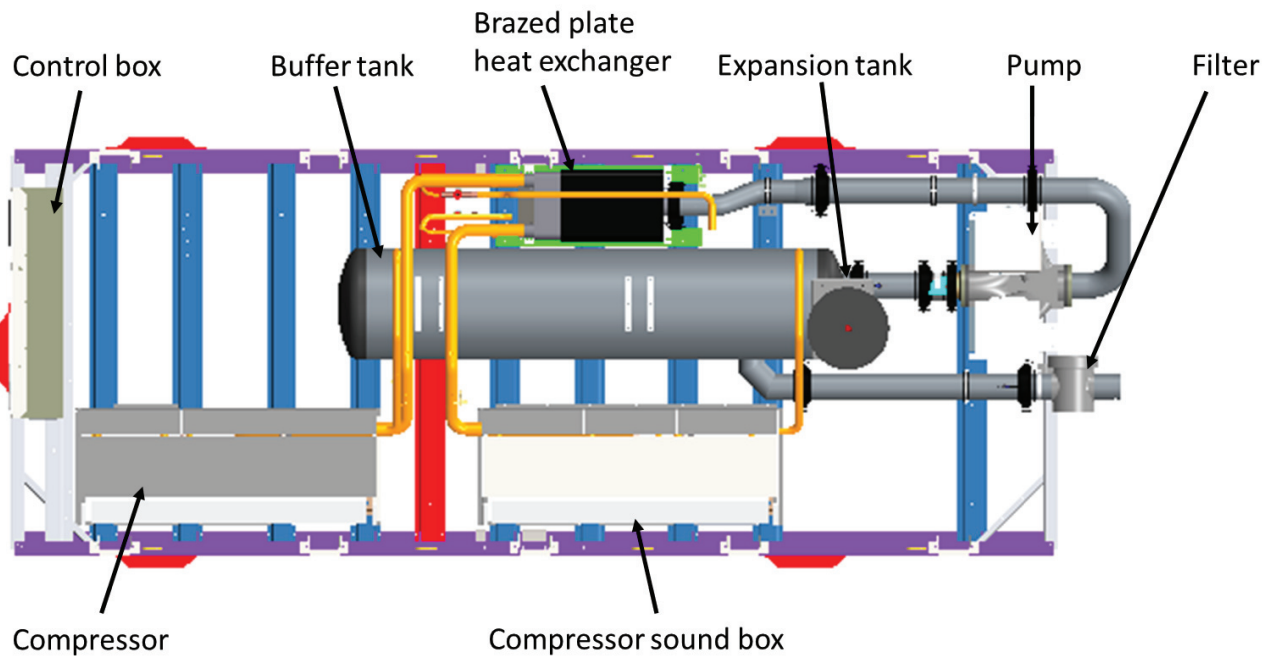

Installation Requirements

Installation Responsibilities

Generally contractor must do the following items when installing a CGAF unit:

1. Install the unit on a flat foundation strong enough to support unit loading and level (within 5 mm across the length and width of the unit).
2. Install the units as per instructions contained in this manual.
3. Where specified, provide and install valves in the water piping upstream and downstream of the evaporator water connections, to isolate the evaporator for maintenance, and to balance and trim the system.
4. Furnish and install a water flow prove device and/or auxiliary contacts to prove chiller water flow.
5. Furnish and install water pressure gauges in the inlet and outlet of the evaporator water box.
6. Supply and install an air vent cock to the top of the evaporator or evaporator piping.
7. Furnish and install strainers ahead of all pumps and automatic modulating valves.
8. Provide and install field wiring according to schematics provided in the control panel.
9. Install heat tape and insulate the chilled water lines and any other portion of the system, as required, to prevent sweating under normal operating conditions or freezing during low ambient temperature conditions.
10. Ensure that the compressor and compressor heaters have been operating for a minimum of 24 hours before starting. Failure to do so may result in equipment damage.
11. Start the unit under supervision of a qualified service technician.

Nameplates

The CGAF outdoor unit nameplates are applied to the exterior of the control panel. A compressor nameplate is located on each compressor.

Unit Nameplate

The unit nameplate provides the following information:

- Unit model and size description
- Unit serial number
- Identifies unit electrical requirements
- Lists correct operating charges of refrigerant and refrigerant oil
- Lists unit test pressures

Compressor Nameplate

The compressor nameplate provides following information:

- Compressor model number.
- Compressor serial number.
- Compressor electrical characteristics.
- Utilization range
- Recommended refrigerant

Storage

Extended storage of the unit prior to the installation requires the following precautions:

1. Store the unit in a secured area, to avoid intentional damages.
2. Close the suction, discharge and liquid-line isolation valves.
3. At least every three months, connect a gauge and manually check the pressure in the refrigerant circuit. If the refrigerant pressure is below 13 Bar at 20°C (or 10 Bar at 10°C), call a qualified service organization and the appropriate Trane sales office.

Note: if the unit is stored before servicing near a construction site it is highly recommended to protect micro channel coils from any concrete and iron element. Failure to do so may considerably reduce reliability of the unit.

Lifting and Moving Instructions

A specific lifting method is recommended, which can be described as follow:

1. Lifting points are built into the unit, see lifting instruction label on the unit.
2. Slings and spreader bar must be provided by crane operator and attached on the lifting points.
3. Use the 4 rigging points which are built into the unit.
4. The minimum lifting capacity of each sling as well as the spreader bar must be higher than the tabulated unit shipping weight.
5. CAUTION! Lift and handle with care. Avoid shocks while handling.

Details of lifting instruction and container pull out are given in the drawings specific for lifting and handling shipped with the unit.

Installation Requirements

WARNING! Heavy Objects!

Ensure that all the lifting equipment used is properly rated for weight of the unit being lifted. Each of the cables (chains or slings), hooks, and shackles used to lift the unit must be capable of supporting the entire weight of unit. Lifting cables (chains or slings) may not be the same length. Adjust as necessary for even unit lift. Other lifting arrangements could cause equipment or property damage. Failure to follow instructions above or properly lift unit could result in unit dropping and possibly crushing operator/technician which could result in death or serious injury.

WARNING! Improper Unit Lift!

Test lift unit approximately 10 cm to verify proper center of gravity lift point. To avoid dropping of unit, reposition lifting point if unit is not level. Failure to properly lift unit could result in unit dropping and possibly crushing operator/technician which could result in death or serious injury and possible equipment or property- only damage.

Dimension and Weights

Dimensions details, dimensions of hydraulic connections, electrical connections, isolator positioning, specific features for heat recovery and free cooling are included in submittals and diagrams provided in documentation package.

Center of Gravity

See instructions on lifting drawings available on request.

Clearances

When installing the unit, provide enough space around the unit to allow the installation and maintenance personnel unrestricted access to all service points. Unobstructed flow of condenser air is essential to maintain chiller capacity and operating efficiency. When determining unit placement, give careful consideration to ensuring a sufficient air flow across the condenser coils heat-transfer surface.

In case of enclosure around the unit, the height of the enclosure must not be higher than the unit itself. If the enclosure is higher than the unit, restrictive airflow louvers should be fitted to ensure fresh air supply.

Unit Isolation and Leveling

Provide a foundation with sufficient strength and mass to support the unit operating weight (that is, including completed piping, full operating charges of refrigerant and oil, and water). Refer to unit operating weights. The unit must be leveled within 5 mm over its length and width. Use shims as necessary to level the unit. For additional reduction of sound and vibration, install the optional elastomeric isolators.

Sound consideration

The most effective form of acoustical isolation is to locate the unit away from any sound sensitive area.

Structurally transmitted sound can be reduced by elastomeric vibration eliminators. Spring isolators are not recommended. Consult an acoustical engineer in critical sound applications.

For maximum isolation effect, isolate water lines and electrical conduit. Rubber isolated piping hangers can be used to reduce the sound transmitted through water piping. To reduce sound transmitted through electrical conduit, use flexible electrical conduit.

EU and Local Regulations codes on sound emissions should always be considered. Since the environment in which a sound source is located affects the sound pressure, unit placement must be carefully evaluated.

Installation Requirements

Elastomeric Isolators Installation (Optional)

Isolators are ready to install. Mountings have to be placed on a rigid and level foundation. External equipment should not transmit additional vibration to the chiller. The position of elastomeric isolator and weight per point are given in the Neoprene isolators installation drawing which is supplied with the chiller. Wrong placement along the unit may result in excessive deflection.

1. Secure the isolators to the mounting surface using the mounting slots in the isolator's base plate. Do NOT fully tighten the isolators mounting bolts at this time. See the isolators submittals for isolators location, maximum weights, and isolators diagrams.
2. Align the mounting holes in the base of the unit with the threaded positioning pins on the top of the isolators.
3. Install the unit on the isolators and secure the isolators to the unit with a nut. The maximum isolators deflection should be 13 mm.
4. Level the unit carefully. Fully tighten the isolator mounting bolts.

Figure 2 – Elastomeric Isolator

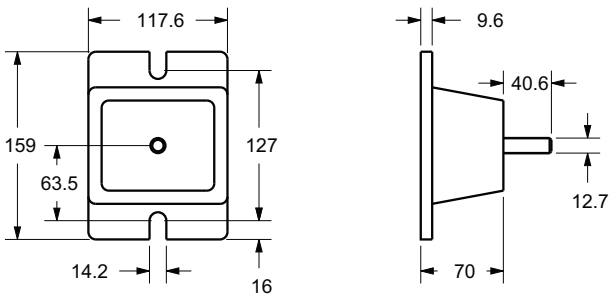

Isolator Pads Installation (Optional)

Isolators are ready to install. Mountings have to be placed on a rigid and level foundation. External equipment should not transmit additional vibration to the chiller. The position of pads isolator is given in the pad isolators installation or selection drawing which is supplied with the chiller.

Figure 3 – Isolator pads

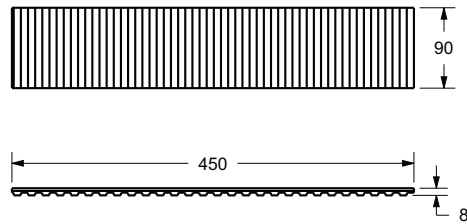

Evaporator Piping

Drainage

A large capacity drain must be provided for water vessel drain-down during shutdown or repair. Water piping is provided with drain connections.

Water Treatment

In the evaporator the following material are in contact with water:

Plate material : AISI 316 EN 10028-7 - 1.4401 +2B/2R

Connection : AISI 316 EN 10272 - 1.4401/1.4404/1.4435/1.4436 - 1E

Braze alloy EN-13388, ISO Copper CU-HCP

When the unit is supplied with hydraulic module, the following additional materials are in contact with water:

- Pump frame and connections are made of cast iron
- Water pipes are made of carbon steel
- Pipe sealings are made of EPDM rubber (ethylene propylene diene monomer rubber)
- Pump sealings are made of silicon carbide
- Strainer is made of stainless steel

Dirt, scale, products of corrosion, and other foreign material will adversely affect heat transfer between the water and system components. Foreign matter in the chilled-water system can also increase pressure drop and consequently, reduce water flow. Proper water treatment must be determined locally, depending on the type of system and local water characteristics.

Neither salt nor brackish water is recommended for use in Trane air-cooled chillers. Use of either will lead to an unpredictably shorter life cycle. Trane encourages the employment of a reputable water treatment specialist, familiar with local water conditions, to assist in this determination and in the establishment of a proper water treatment program.

CAUTION! If using an acidic commercial flushing solution, construct a temporary bypass around the unit to prevent damage to internal components of the evaporator. Trane assumes no responsibility for equipment failures which results from untreated or improperly treated water or saline or brackish water. If calcium chloride is used for water treatment, an applicable corrosion inhibitor must also be used. Failure to do so may result in damage to system components. Do not use untreated or improperly treated water. Equipment damage may occur.

Evaporator water connections are grooved. Thoroughly flush all water piping to the unit before making the final piping connections to the unit. Components and layout will vary slightly, depending on the location of connections and the water sources.

An air vent is located on top of the evaporator at the chiller water outlet. Be sure to provide additional air vents at the highest points in the piping to remove air from the chilled water system. Install necessary pressure gauges to monitor the entering and leaving chilled water pressure.

Provide shut off valves in lines to the gauges to isolate them from the system when they are not in use. Use rubber vibration eliminators to prevent vibration transmission through the water lines.

If desired, install thermometers in the lines to monitor entering and leaving water temperatures. Install a balancing valve in the leaving water line to control water flow balance. Install shutoff valves on both the entering and leaving water lines so that the evaporator can be isolated for service.

It is mandatory to place a flow switch device at the outlet of the unit and to link it with the control of the unit (see wiring diagrams shipped with the unit).

Piping components include all devices and controls used to provide proper water system operation and unit operating safety. A typical CGAF evaporator piping is shown below.

Figure 4 – Unit typical water circuit

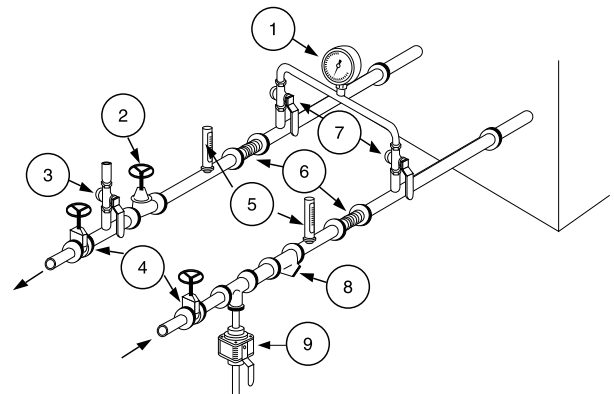

- 1 = Pressure gauges: show entering and leaving water pressure
- 2 = Balancing valve: adjusts water flow.
- 3 = Air purge allows to remove the air from the water circuit during fill up.
- 4 = Stop valves: isolate chillers and water circulating pump during maintenance operations.
- 5 = Thermometers: indicate chilled water entering and leaving temperatures.
- 6 = Expansion compensators: avoid mechanical stress between chiller and piping installation.
- 7 = Stop valve located on the outlet connection: used to measure the water pressure inlet or outlet of evaporator.



Evaporator Piping

8 = Strainer: avoid to get heat exchangers dirty. All installation must be equipped with efficient strainer in order that only clean water enters into exchanger. If there is no strainer, reserve will be formulated by the Trane technician at the start-up of the unit. The trainer used must be able to stop all particles with a diameter greater than 1 mm.

9 = Draining: used as the draining the plate heat exchanger.

Do not start the unit with low water volume or not enough pressurized circuit.

Note: A pressure switch device to detect lack of water is not included in the pump package. Installation of this type of device is highly recommended to avoid sealing damage due to operation of pump without enough water.

CAUTION! The chilled-water connections to the evaporator are to be “grooved pipe” type connections. Do not attempt to weld these connections, because the heat generated from welding can cause microscopic and macroscopic fractures on the heat exchanger connection that can lead to premature failure of the connection. An optional grooved pipe stub and coupling should be used for welding on flanges.

To prevent damage to chilled-water components, do not allow evaporator pressure (maximum working pressure) to exceed 10 Bar. The maximum service pressure depends on free cooling type and potential pump package option. The value of max service pressure is indicated on unit nameplate.

Entering Chilled Water Piping

- Air vents to bleed the air from the system (to be placed on the highest point)
- Water pressure gauges with shutoff valves
- Vibration eliminators
- Shutoff (isolation) valves
- Thermometers if desired (temperature readings available on chiller controller display)
- Clean-out tees
- Pipe strainer

Leaving Chilled Water Piping

- Air vents to bleed the air from the system (to be placed on the highest point)
- Water pressure gauges with shut off valves
- Vibration eliminators
- Shutoff (isolation) valves
- Thermometers (temperature readings available on the chiller controller display)
- Clean-out tees
- Balancing valve
- Flow Proving Device

Pressure Gauges

Install field-supplied pressure components. Locate pressure gauges or taps in a straight run of pipe; avoid placing them near elbow (at least at 10 pipe diameter from discontinuity).

To read manifold pressure gauges, open one valve and close the other (depending on the side of the desired reading), this eliminate errors resulting from differently calibrated gauges installed at unmatched elevations.

Evaporator Flow Switch

Specific connection and schematic wiring diagram are shipped within the unit. Some piping and control schemes, particularly those using a single water pump for both chilled and hot water, must be analyzed to determine how and/or if a flow sensing device will provide the desired operation.

Flow Switch Installation – Typical Requirements

1. Mount the switch upright, with a minimum of 5 pipes diameters of straight horizontal run on each side. Do not install close to elbows, orifices, or valves. The arrow on the switch must point in the direction of the flow.
2. To prevent switch fluttering, remove all air from the water system. Tracer UC800 provides a 6 second time delay after a “loss-of-flow” diagnostic before shutting the unit down. Contact a Trane service representative if nuisance machine shutdowns persist.
3. Adjust the switch to open when water flow falls below nominal values. Evaporator data is given on the General Information Section. Flow Switch contacts are closed on proof of water flow.

CAUTION! Control voltage from the chiller to the flow proving device is 110V AC.

Note: In case of winter water drainage for freeze protection, it is mandatory to disconnect the evaporator’s heaters to protect them from burning due to overheat. It is also mandatory to fulfill the drainage, using pressurized air, and ensure that no water stays in the evaporator during winter season.

Evaporator Piping

Figure 5 – CGAF Evaporator Water Pressure Drop

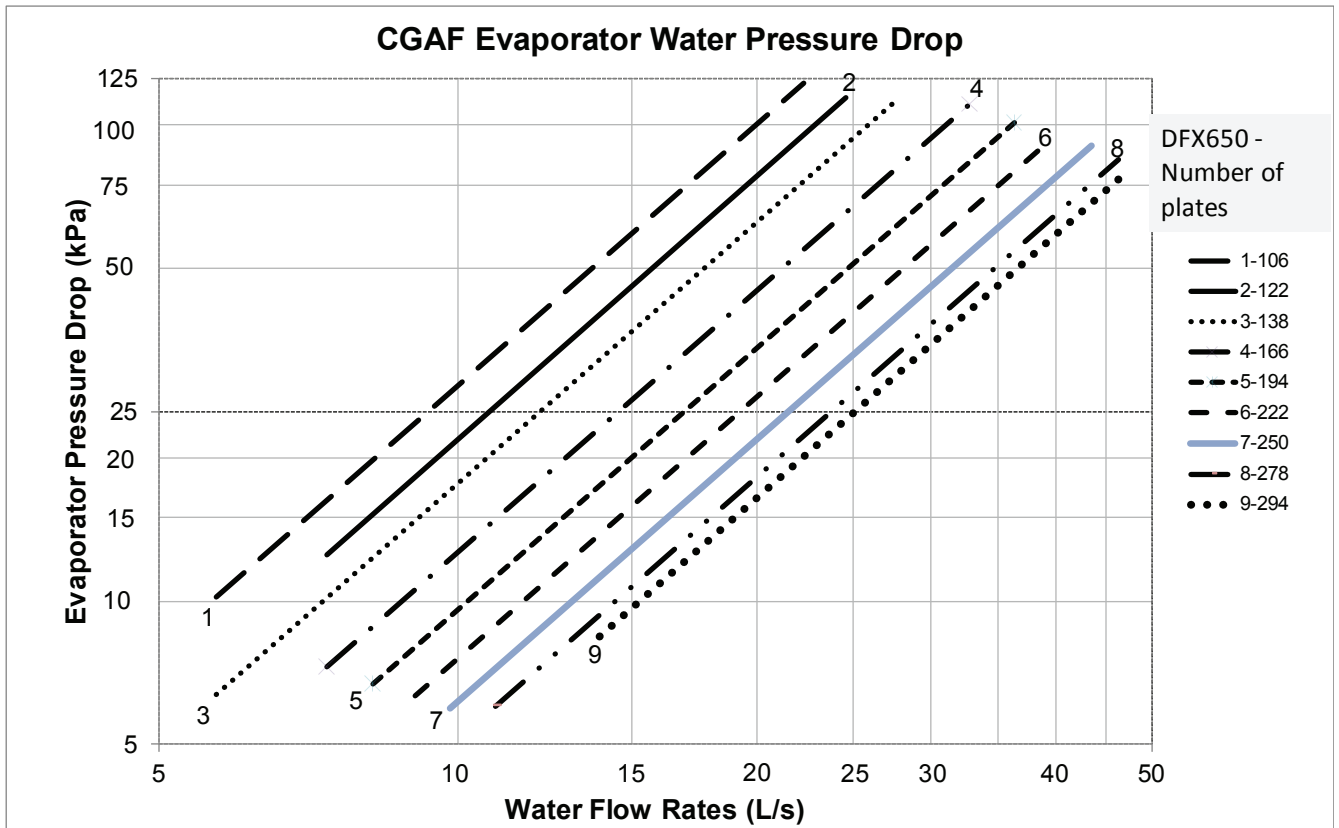

Note:

Water pressure drop are for pure water.
Limit of water flow are limit of the curves.



Installation - Mechanical

Hydraulic module

Chiller can be ordered with an optional integrated hydraulic module. In this case, chiller will be provided with the following components factory mounted and tested:

- Centrifugal water pump, Low pressure or High pressure (option)
- Water strainer to protect the pump against impurities in the circuit
- Expansion module with expansion vessel and pressure relief valve sufficient to ensure the expansion of the water loop ability
- Thermal insulation for antifreeze protection
- Balancing valve for equilibrate the flow of water circuit
- Drain valve
- Temperature sensor

Note: A pressure switch device to detect lack of water is not included in the pump package. Installation of this type of device is highly recommended to avoid sealing damage due to operation of pump without enough water.

Installation - Mechanical

Pump package schematics

Pump package schematics is supplied in the documentation set shipped with the unit.

ITEM	DESIGNATION
1	CENTRIFUGAL PUMP SINGLE OR DUAL
2	WATER STRAINER
3	BUTTERFLY VALVE
4	BALANCE VALVE
5	VALVE FOR PRESSURE POINT
6	EXPANSION TANK
7	WATER PRESSURE RELIEF VALVE
8	EXCHANGER

ITEM	DESIGNATION
9	AUTOMATIC AIR BLEED
10	MANUAL AIR BLEED
11	DRAIN VALVE
12	ANTIFREEZE PROTECTION
13	BUFFER TANK
15	INVERTER

ITEM	DESIGNATION
(F)	WATER FLOW SWITCH
(T1)	EVAP WATER INLET TEMP SENSOR
(T2)	EVAP WATER OUTLET TEMP SENSOR

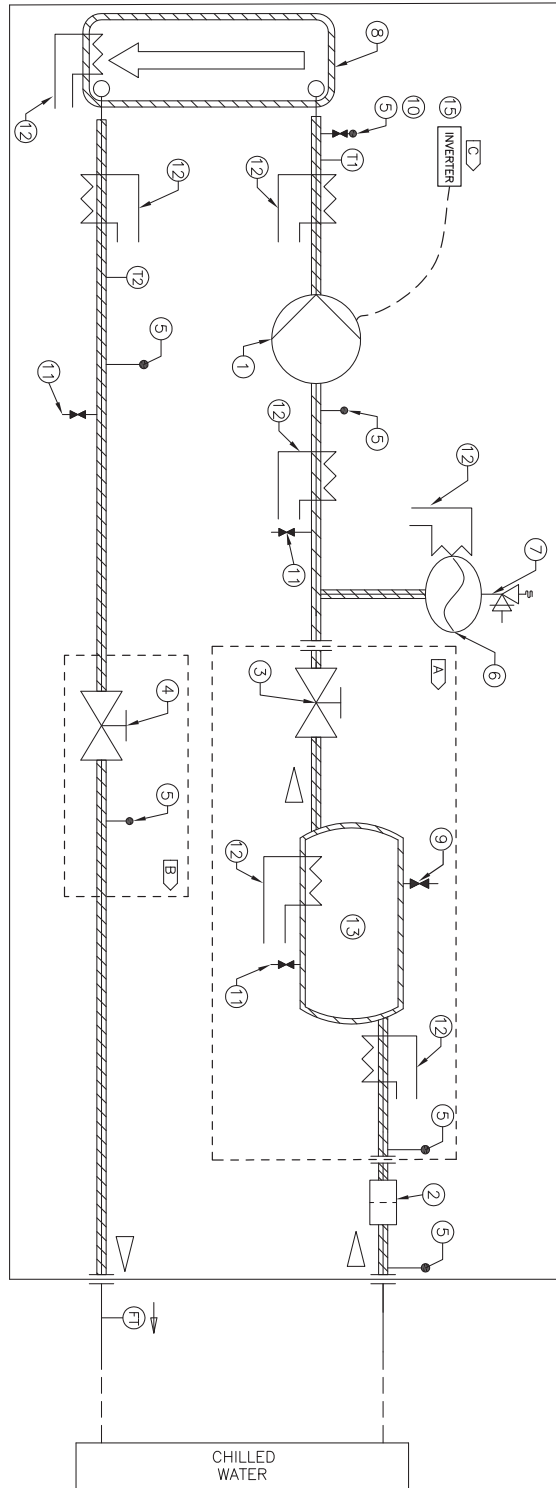

	WATER LINE
	INSULATED WATER LINE

- OPTIONAL BUFFER TANK
- OPTIONAL BALANCING VALVE
- OPTIONAL AFD

Installation - Mechanical

Pump Curves

Figure 6 – Pump Curve - Sizes 090-190

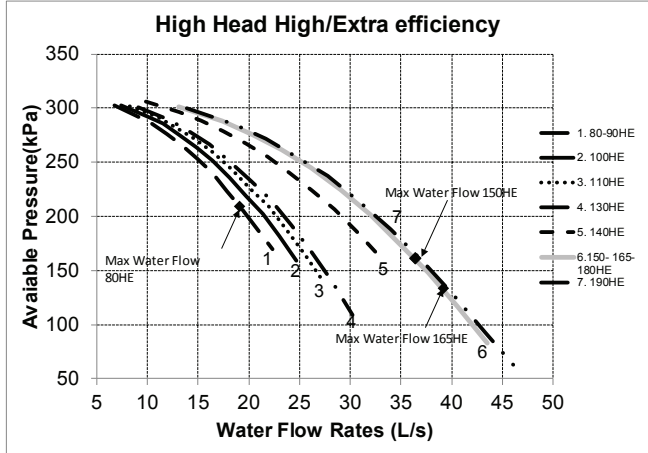
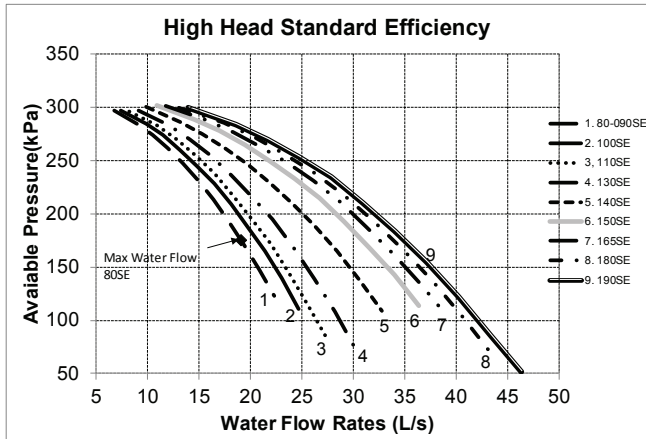
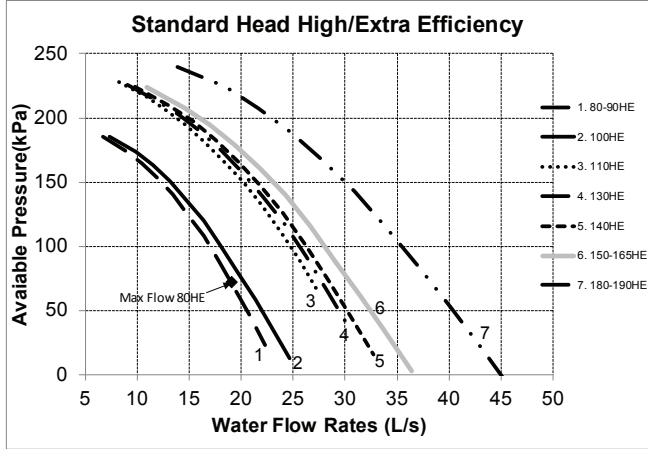
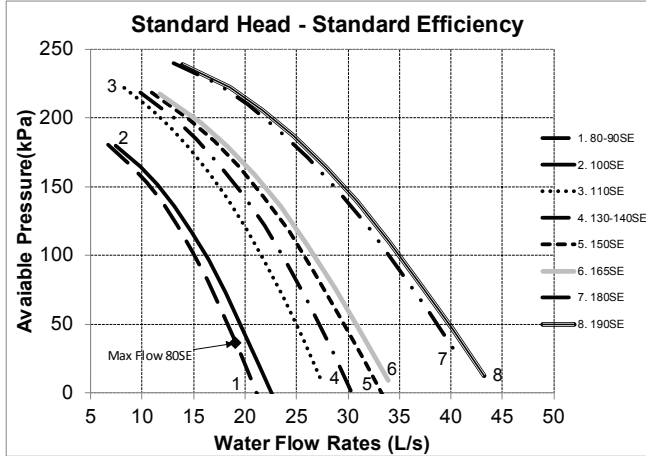

Installation - Mechanical

Heat recovery option is made with a plate heat exchanger in series with the air-cooled condenser. This heat exchanger benefits the discharge gas superheat as well as a part of the condensing gas heat to be transferred to hot water system.

PHR data are included in the general data tables.

Figure 7 – Water pressure drop - heat recovery heat exchanger

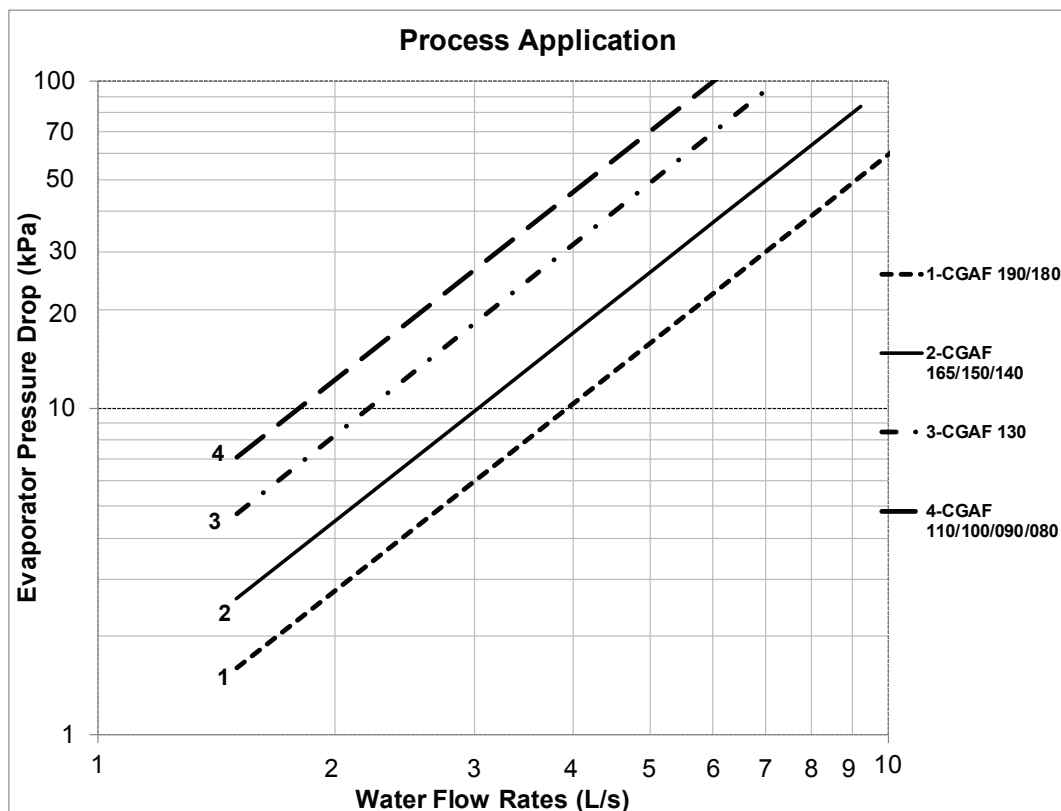
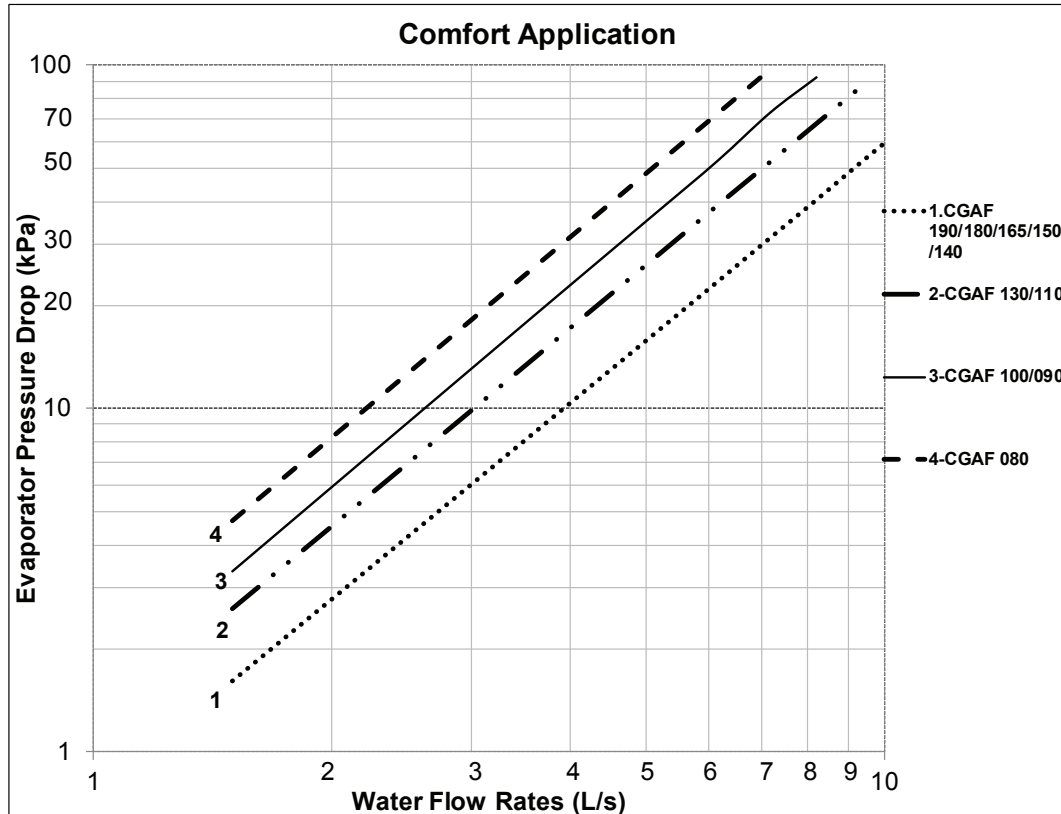



Evaporator Waterside

Freeze Protection

Depending on the ambient temperature the unit may be exposed to freeze, there are multiple options for freeze protection. They are listed in order of highest ambient (least freeze protection) to the lowest ambient (most freeze protection).

For all chiller running with water under cold ambient temperature (below 0°C), it is extremely important to keep full water flow in the evaporator for an extended time after last compressor stops. This will protect brazed plate evaporator from freezing by refrigerant migration. This is why evaporator water pump output relay must be used to control the chilled water pump. This is not mandatory if glycol is used with protection down to lowest ambient expected.

1. Water pump and heaters

- Heaters are factory installed on brazed plates evaporator. They will protect it from freezing in ambient temperatures down to -18°C. Heaters are installed on the water piping and on the pumps of units equipped with hydraulic module.
- Install heat tape on all water piping, pumps, and other components that may be damaged if exposed to freezing temperatures. Heat tape must be designed for low ambient temperature applications. Heat tape selection should be based on the lowest expected ambient temperature.
- Tracer™ UC800 controller can start the pump(s) when freezing conditions are detected. For this option the pumps must be controlled by the CGAF unit and this function validated on the chiller controller.
- Water circuit valves need to stay open at all times.

Note: Water pump control and heater combination will protect the evaporator down to any ambient temperature provided power is available to the pump and the UC800 controller. This option will NOT protect the evaporator in the event of power failure to the chiller unless backup power is supplied to the necessary components.

OR

2. Freeze inhibitor

- Freeze protection can be accomplished by adding sufficient glycol to protect against freezing down to the lowest ambient expected.
- See “evaporator glycol requirement” section for guidance on determining the glycol concentration.

Note: Use of glycol type antifreeze reduces the cooling capacity of the unit and must be considered in the design of the system specifications.

CAUTION! When using freeze inhibitor, never fill the system with pure glycol.

Always fill the system with diluted solution. Maximum concentration of glycol is 40%. Higher glycol concentration will damage pump seal.

OR

3. Drain water circuit

For ambient temperatures below -20°C and for those installation not including either option 1 or 2 above described

- Shut off power supply to unit and to all heaters.
- Purge the water circuit
- Blow out the evaporator to ensure that no liquid is left inside the evaporator and the water lines. Drain the pump.

Note: It is not recommended to drain the water circuit for the following reasons.

- The water circuit will rust and its lifetime could be reduced.
- Water will remain in the bottom of the plate heat exchangers and freeze damage could occur

CAUTION! Evaporator damage!

If insufficient concentration or no glycol is used, the evaporator water pumps must be controlled by the UC800 to avoid severe damage to the evaporator due to freezing. A power loss of 15 minutes during freezing can damage the evaporator. It is the responsibility of the installing contractor and/or the customer to ensure that a pump will start when called upon by the chiller controls. Please consult Trane service for unit setting and % of glycol required.

With factory-fitted disconnect switch option, evaporator trace heating is taken from the live side of the isolator. As a consequence, the heaters are energized as long as the main switch is closed. Supply voltage to the heating tapes is 400V.

- Avoid the use of very low or near minimum chilled fluid flow rates through the chiller. Higher velocity chilled fluid flow reduces freeze risk in all situations.
- Flow rates below limits have increased freeze potential and have not been considered by freeze protection algorithms.
- Avoid applications and situations that result in a requirement for rapid cycling or repeated starting and stopping of the chiller. Keep in mind that chiller control algorithms may prevent a rapid compressor restart after shutting down when the evaporator has been operating near or below the LERTC (Low Refrigerant Temperature Cutout) limit.
- Maintain refrigerant charge at appropriate levels. If charge is in question, contact Trane service. A reduced or low level of charge can increase the likelihood of freezing conditions in the evaporator and/or LERTC diagnostic shutdowns.

The warranty will be void, in case of freezing due to the lack of use of either of these protections.

Evaporator Waterside (not for free cooling version)

Low refrigeration temperature setpoint and antifreeze setpoint on CGAF unit control

CAUTION! The chiller is provided with standard factory settings. It can be necessary to modify the Low Pressure saturation Temperature and the Antifreeze Setpoint on the unit control. Based on the following examples, it is necessary to modify on the unit control the following settings:

- The LP saturation temperature
- The antifreeze setpoint

Examples

For:

- 7°C, the LP setting must be -4°C where the antifreeze setting shall be 2°C
- 2°C, the LP setting must be -9°C where the antifreeze setting shall be -4°C
- -12°C, the LP setting must be -23°C where the antifreeze setting shall be -17°C

Freeze protection with glycol

It is mandatory to use a freeze inhibitor for leaving water setpoint less or equal to 5°C. On the glycol recommended concentration figure, you must select concentration on or above the curve. For example, for -4°C brine temperature, a concentration of 25% ethylene glycol is not sufficient. The concentration must be 28% ethylene glycol or 33% propylene glycol.

Using glycol with hydraulic module

If the glycol brine percentage is not at the recommended percentage (greyed area), corrosion inhibitor present in the glycol may not be efficient enough. For instance, a glycol concentration of 15% will provide freeze protection to the unit down to -5°C, but it might generate additional corrosion.

Figure 8 – LP setting Vs. Leaving Water Temperature setpoint

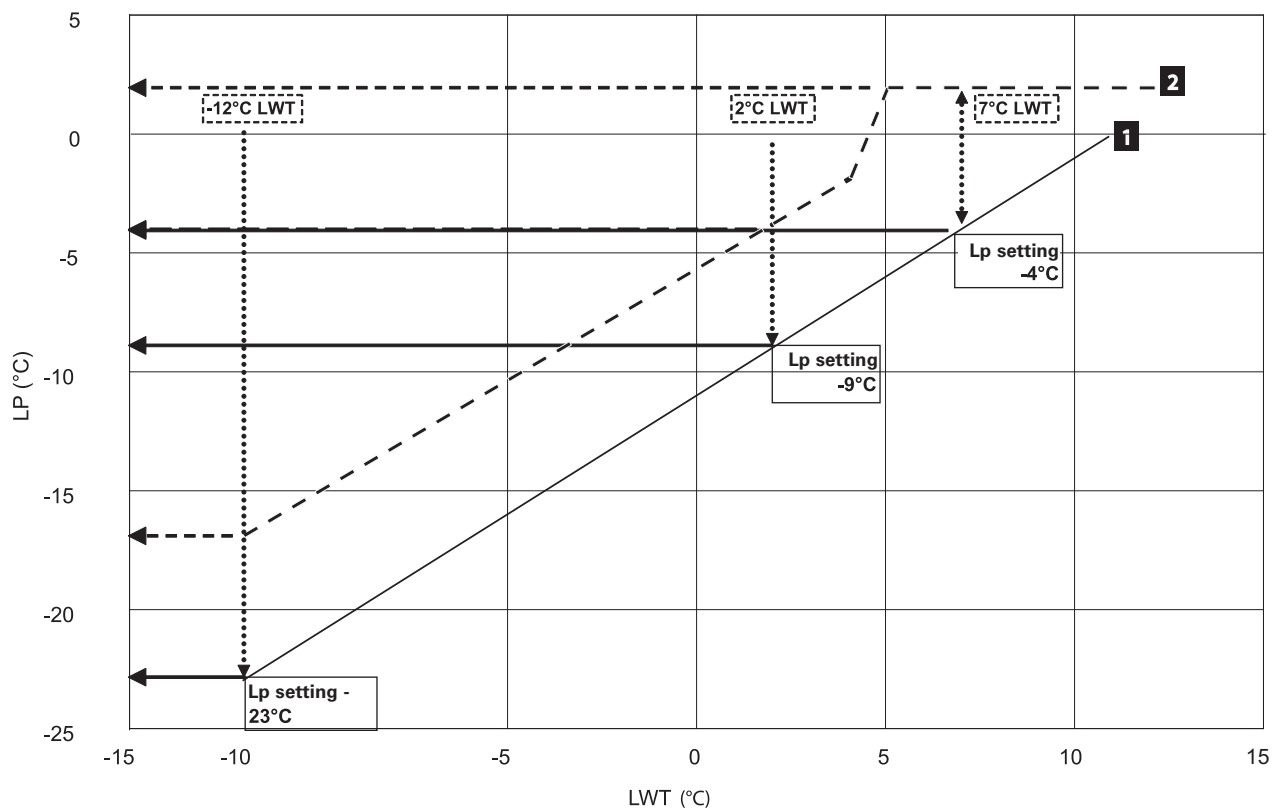

Evaporator Waterside (not for free cooling version)

Figure 9 – Glycol percentage recommendation curve

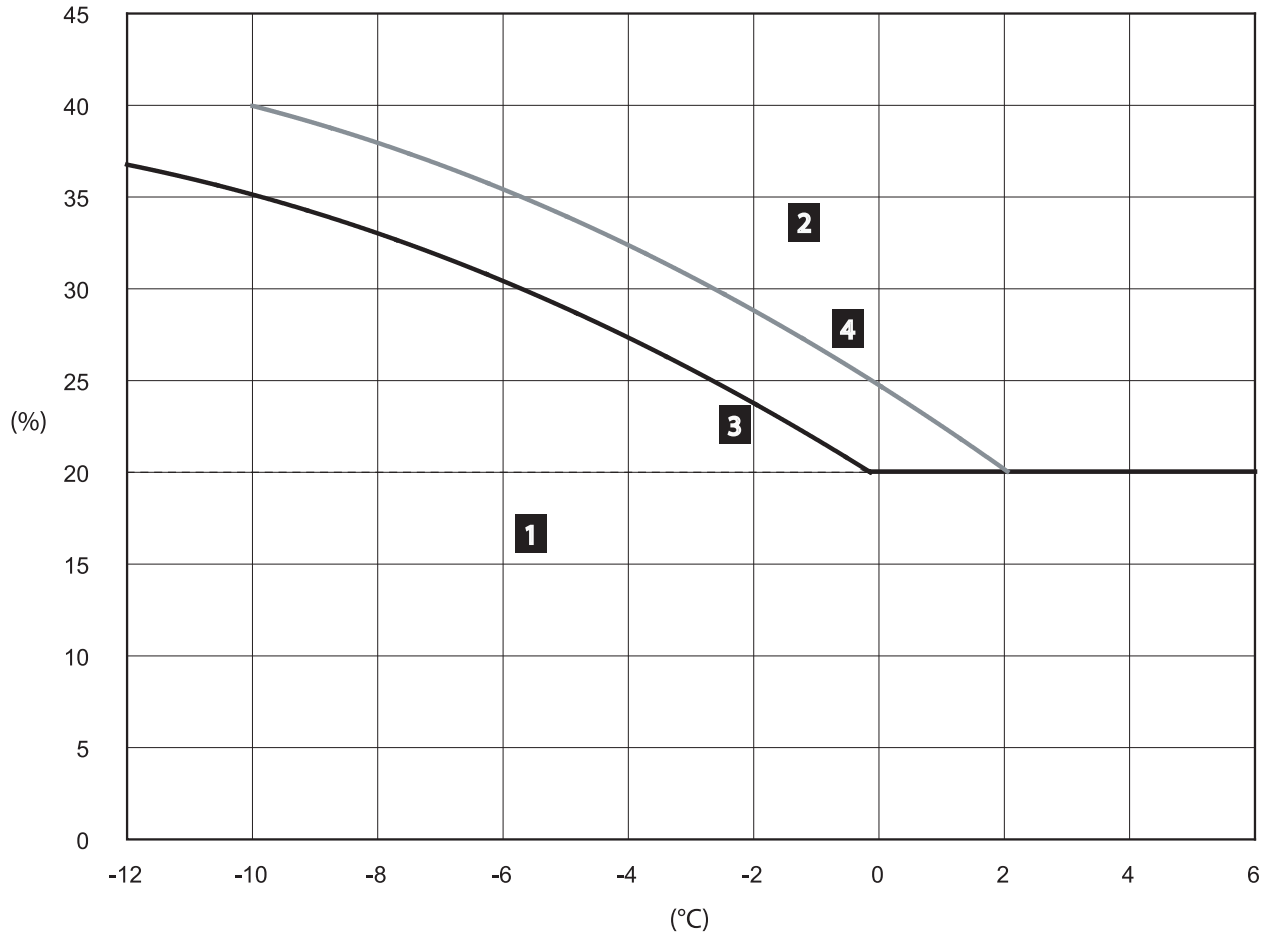

- 1 = Critical risks of freezing
- 2 = Efficient freeze protection
- 3 = Ethylene glycol
- 4 = Propylene glycol
- % = Glycol percentage (mass concentration)
- °C = Glycol or water temperature

CAUTION!

1. Additional glycol beyond the recommendations will adversely affect unit performance. The unit efficiency will be reduced and the saturated evaporator temperature will be reduced. For some operating conditions this effect can be significant.
2. If additional glycol is used, then use the actual % glycol to establish the low refrigerant cutout set point with Trane service advice.
3. The minimum low refrigerant cutout set point allowed is - 20.6°C. This minimum is established by the solubility limits of the oil in the refrigerant.
4. With glycol application, ensure that there is no fluctuation of brine flow versus Order Write Up value, as a reduction of flow will adversely affect unit performance and behaviour.
5. Full unit simulation is required for proper prediction of unit performance for specific operating conditions. For information on specific conditions, contact Trane.

General Electrical Recommendations

Electrical Parts

When reviewing this manual keep in mind.

- All field-installed wiring must be in accordance with local regulations, CE directives and guidelines. Be sure to satisfy proper equipment grounding requirements according CE
- The following standardized values - Maximum Amps - Short Circuit Amps - Starting Amps are displayed on unit nameplate.
- All field-installed wiring must be checked for proper terminations, and for possible shorts or grounds.

Note: always refer to wiring diagrams shipped with chiller or unit submittal for specific electrical schematic and connection information.

Important: to prevent control malfunctions, do not run low voltage wiring (<30V) in conduit with conductors carrying more than 30 volts.

WARNING! Hazardous Voltage with Capacitor!

Disconnect all electric power, including remote disconnects and discharge all motor start/run and AFD (Adaptive Frequency™ Drive) capacitors before servicing. Follow proper lockout/tagout procedures to ensure the power cannot be inadvertently energized.

- For variable frequency drives or other energy storing components provided by Trane or others, refer to the appropriate manufacturer’s literature for allowable waiting periods for discharges capacitors. Verify with an appropriate voltmeter that all capacitors have discharged
- DC bus capacitors retain hazardous voltages after input power has been disconnected. Follow proper lockout/tagout procedures to ensure the power cannot be inadvertently energized

After disconnecting input power, wait five (5) minutes for units which are equipped with EC fans and wait twenty (20) minutes for units which are equipped with variable frequency drive (0V DC) before touching any internal components.

Failure to follow these instructions could result death or serious injury

For additional information regarding the safe discharge of capacitors, see “Adaptive Frequency™ Drive (AFD3) Capacitor Discharge” and BAS-SVX19B-E4.

Hazardous Voltage – Pressurized Burning Fluid!

Before removing compressor terminal box cover for servicing, or servicing power side of control panel, CLOSE COMPRESSOR DISCHARGE SERVICE VALVE and disconnect all electric power including remote disconnects. Discharge all motor start/run capacitors. Follow lockout/tagout procedures to ensure the power cannot be inadvertently energized. Verify with an appropriate voltmeter that all capacitors have discharged.

The compressor contains hot, pressurized refrigerant. Motor terminals act as a seal against this refrigerant. Care should be taken when servicing NOT to damage or loosen motor terminals.

Do not operate compressor without terminal box cover in place.

Failure to follow all electrical safety precautions could result in death or seriously injure.

CAUTION! To avoid corrosion, overheating or general damage, at terminal connections, unit is designed for copper mono-conductors only. In case of multiconductor cable, an intermediate connection box must be added. For cable with alternative material, bi-material connecting devices are mandatory. Cable routing inside control panel should be made case by case by installer. Do not allow conduit to interfere with other components, structural members or equipment. Control voltage (115V) wiring in conduit must be separate from conduit carrying low voltage (<30V) wiring. To prevent control malfunctions, do not run low voltage wiring (<30V) in conduit with conductors carrying more than 30V.

WARNING!

The Warning Label is displayed on the equipment and shown on wiring diagrams and schematics. Strict adherence to these warnings must be observed. Failure to do so may result in personal injury or death.

CAUTION! Units must not be linked to the neutral wiring of the installation. Units are compatible with the following neutral operating conditions:

TNS	IT	TNC	TT
Standard	Special	Special	Standard*

* Differential protection should be suited for industrial machinery with current leak which can be higher than 500 mA (several motors and frequency drives).



General Electrical Recommendations

Electrical data

Refer to General Data tables for each unit configuration and size.

- Maximum Power input (kW)
- Unit rated amps (Max compr +Fan+Control)
- Unit start up amps (Starting Amps of the largest compr+RLA of 2nd compr+RLA of all fans+ control)
- Compressor Power factor
- Disconnect switch size (A)
- Short Circuit Rating for all sizes =35 kA

For the control of every unit

- Max power input is 1.4 kW
- Max Amps is 3.4 A

Wiring diagrams are shipped with unit and can be found in the unit control panel.

Note : Rating is made for 400 V, 3 phases, 50 Hz power supply.

Installer-Supplied Components

Customer wiring interface connections are shown in the electrical schematics and connection diagrams that are shipped with the unit. The installer must provide the following components if not ordered with the unit:

- Power supply wiring (in conduit) for all field-wired connections
- All control (interconnecting) wiring (in conduit) for field supplied devices
- Fused-disconnect switches

Power Supply Wiring

All power supply wiring must be sized and selected accordingly by the project engineer in accordance with standard IEC 60364. All wiring must comply with local codes. The installing (or electrical) contractor must provide and install the system interconnecting wiring, as well as the power supply wiring. It must be properly sized and equipped with the appropriate fuse-disconnect switches. The type and installation location(s) of the fused-disconnect switches must comply with all applicable codes.

Cut holes into the sides of the control panel for the appropriately-sized power wiring conduits. The wiring is passed through these conduits and connected to the terminal blocks.

To provide proper phasing of 3 phase input, make connections as shown in field wiring diagrams and as stated on the yellow WARNING label in the starter panel. Proper equipment grounds must be provided to each ground connection in the panel

CAUTION! Customer wiring interface connections are shown in the electrical schematics and connection diagrams that are shipped with the unit. The installer must provide the following components if not ordered with the unit.

WARNING! To prevent injury or death, disconnect all electrical power sources before completing wiring connections to the unit.

CAUTION! The use of copper mono-conductors is the preferred solution to avoid corrosion and overheating at terminal connections.

Control Power Supply

Chiller is provided with control power transformer, it is not necessary to provide additional control power voltage to the unit.

Heater Power Supply

The evaporator shell is insulated from ambient air and protected from freezing for temperature down to -20°C by two thermostatically-controlled immersion heaters combined with evaporator pumps activation through Tracer UC800. Whenever the ambient temperature drops below 0°C the thermostat energizes the heaters

and the Tracer UC800 activates the pumps. If ambient temperatures below -20°C are expected, contact your Trane local office.

CAUTION! The control panel main processor does not check for loss of power to the heat tape nor does it verify thermostat operation. A qualified technician must frequently verify power to the heat tape and confirm operation of the heat tape thermostat, to avoid catastrophic damage to the evaporator.

CAUTION! With factory-fitted disconnect switch, trace heating is taken from the live side of the isolator so power remains on. Supply voltage to the heating tapes is 400V.

In case of winter water drainage for freeze protection, it is compulsory to disconnect the evaporator heaters to protect them from burning due to overheat.

Water Pump Power Supply

Provide power-supply wiring with fused disconnect switch(es) for the chilled water pump(s).

Interconnecting Wiring

Chilled-Water Flow (Pump) Interlock

CGAF requires a field-supplied, control-voltage contact input through a flow proving switch (6S51) and an auxiliary contact (6K51). Connect the proving switch and auxiliary contact to terminal 2 connector J2 cards (1A11). Refer to the field wiring diagram for details.

Chilled-Water Pump Control

An evaporator water-pump output relay closes when the chiller is given a signal to go into the AUTO mode of operation from any source. The contact is opened to turn off the pump in the event of most machine-level diagnostics, to prevent the buildup of pump heat.

CAUTION! The evaporator water pump output relay must be used to control the chilled water pump and to benefit from the water pump timer function at startup and shutdown of the chiller. This is required when the chiller is in operation under freezing conditions, especially if the chilled water loop does not contain glycol.

CAUTION! Refer to Freeze Protection section for information about the evaporator circulating pump.

Alarm and Status Relay Outputs (Programmable Relays)

See CGAF **User Guide** for alarm and status relay outputs.

EDLS and ECWS Analog Input Signal Wiring Details

See CGAF **User Guide** for EDLS and ECWS.



Operating principles

This section contains an overview of the operation of CGAF air-cooled liquid chiller equipped with microcomputer-based control system.

Note: To ensure proper diagnosis and repair, contact a qualified service organization if a problem could occur.

General

The Model CGAF units are scroll compressor(s), single or dual circuit, air-cooled liquid chillers. These units are equipped with unit-mounted starter/control panels and operate with R410A refrigerant.

The basic components of a CGAF unit are:

- Unit-mounted panel containing starter and Tracer UC800 controller and Input/Output LLIDS
- Scroll compressors
- Brazed plate evaporator
- Air-cooled MCHE condenser with subcooler
- Electronic Expansion Valve (EEXV)
- Related interconnecting piping.

Refrigerant Cycle

The refrigeration cycle of the Model CGAF chiller is conceptually similar to other Trane air-cooled chiller products. The CGAF chiller uses a brazed plate evaporator and an air-cooled MCHE condenser. The compressors use suction gas cooled motors and an oil management system to provide almost oil-free refrigerant to the condenser and evaporator

for maximum heat transfer while lubricating and sealing compressor rotors and bearings. The lubrication system helps to assure long compressor life and contributes to quiet operation.

Refrigerant condenses in the MCHE air-cooled heat exchanger. Liquid refrigerant is metered into the brazed plate evaporator using an electronic expansion valve to maximize chiller efficiency at full and part load operation.

The CGAF chiller is equipped with a unit-mounted starter and control panel. Microprocessor based unit control modules (Trane Tracer™ UC800) provide accurate chilled water control and providing monitoring, protection and adaptive limit functions. The adaptive nature of the controls intelligently prevent the chiller from operating outside of its limits, or compensates for unusual operating conditions while keeping the chiller running rather than simply shutting off the chiller. If problems do occur, the UC800 controls provide diagnostic messages to help the operator in troubleshooting.

Oil System

The oil is efficiently separated inside the scroll compressor and will remain in the scroll compressor during all run cycles. Between 1-2% of the oil circulates around with the refrigerant.

See compressor section for oil level information.

Condenser and Fans

The air cooled Microchannel condenser coils use all aluminum brazed fin construction.

The coil is composed of three components: the flat microchannel tube, the fins located between the microchannel tubes, and two refrigerant manifolds. Coils can be cleaned with high pressure water (see Condenser Coils MCHE maintenance for instructions).

The condenser coil has an integral subcooling circuit.

Condensers are factory proof and leak tested at 45 bars.

Direct-drive vertical-discharge airfoil condenser fans are dynamically balanced.

Operating principles

This section describes the overall flow chart principle for CGAF. Detailed information for a given order is supplied with order package documentation.

Figure 10 – Example of Typical Refrigerant System Schematic & Oil Lube Circuit Schematic

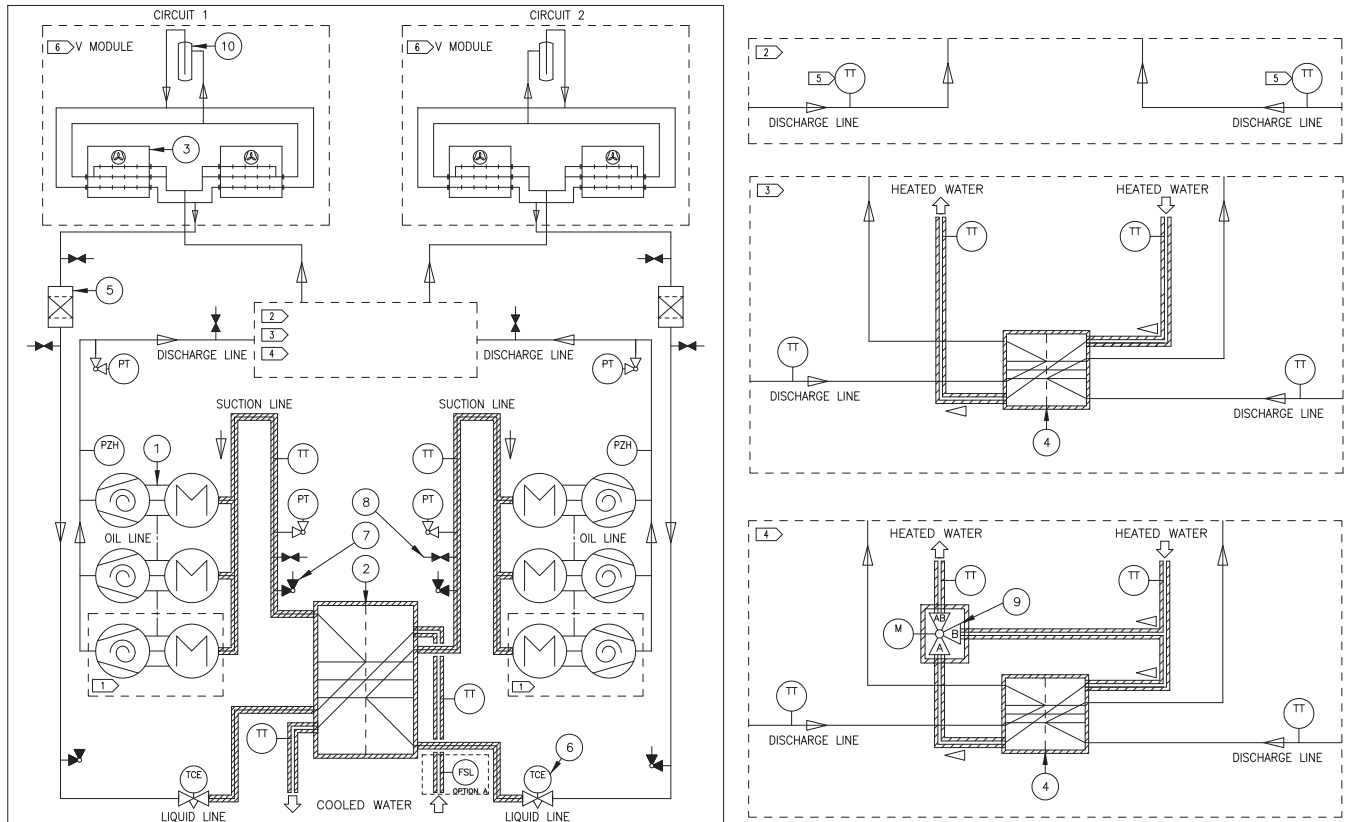

ITEM	DESIGNATION
1	SCROLL COMPRESSOR
2	EVAPORATOR (PLATE HEAT EXCHANGER)
3	CONDENSER (AIR COOLED EXCHANGER)
4	HEAT RECOVERY EXCHANGER (PLATE HEAT EXCHANGER)
5	FILTER DRIER
6	ELECTRIC EXPANSION VALVE
7	SERVICE VALVE
8	SCHRAEDER VALVE
9	3 WAY VALVE
10	RECEIVER

ITEM	DESIGNATION
PT	PRESSURE TRANSDUCER
PZH	HIGH PRESSURE SWITCH
TT	TEMPERATURE SENSOR
TCE	ELECTRIC EXPANSION VALVE
FSL	EVAPORATOR WATER FLOW SWITCH
M	3 WAY VALVE MOTOR

	REFRIGERANT LINE
	OIL LINE
	CHILLED / HEATED WATER LINE
	INSULATION

OPTION A : FLOW SWITCH FSL

- 1 ONLY FOR CGAF 140-150-165-180-190
- 2 COOLING ONLY UNIT
- 3 PARTIAL HEAT RECOVERY OPTION
- 4 TOTAL HEAT RECOVERY OPTION
- 5 ONLY FOR LOW LEAVING WATER TEMPERATURE
- 6 V MODULE DETAILS REFER TABLE BELOW

Operating Map

CGAF SE (Standard or Low ambient)

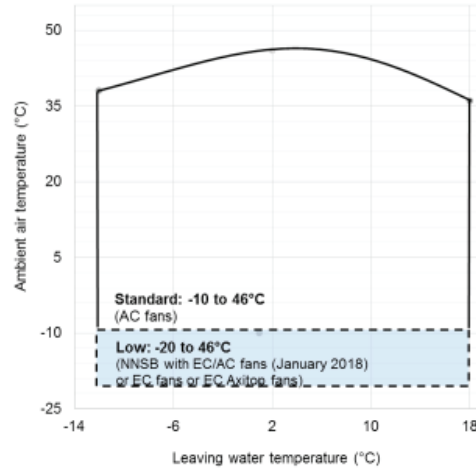

CGAF HE (High or wide ambient)

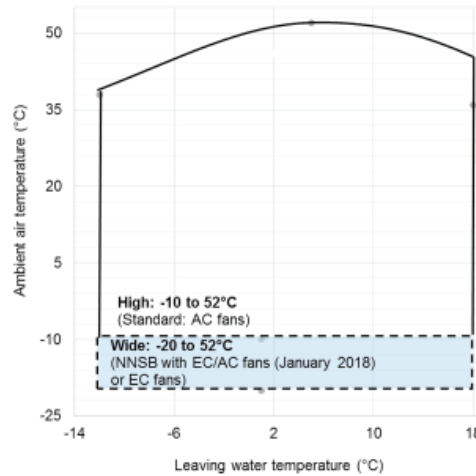

CGAF XE (Wide ambient)

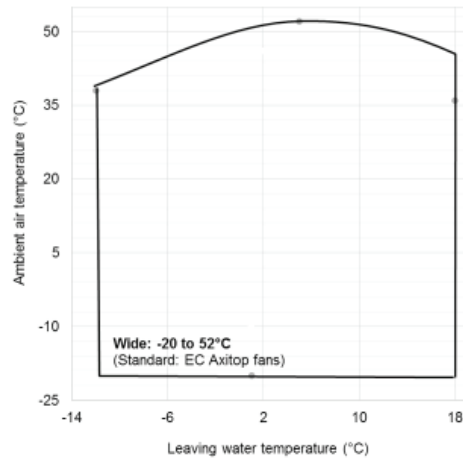

Notes:

- Minimum start-up/operation at low ambient air temperature based on wind speed lower than 2m/s.
- Maximum ambient operation is for unit at 12°C/7°C operating conditions.
- The curve of limit current may vary from one machine size to another, but it will always be a parallel curve to that shown in the operating map.

Controls Overview

Sintesis CGAF units use the following control/interface components:

- Tracer™ UC800 Controller
- TracerTD7 Operator Interface

Communication Interfaces

There are four connections on the UC800 that support the communication interface. See User Guide to locate the following ports: “Wiring and Ports Description” section.

- BACnet MS/TP
- MODBUS Slave
- LonTalk using LCI-C (from the IPC3 bus)

See User Guide for information on communication interface.

Tracer TD7 Operator Interface

Operator Interface

Information is tailored to operators, service technicians and owners. When operating a chiller, there is specific information you need on a day-to-day basis, like setpoints, limits, diagnostic information, and reports.

Day-to-day operational information is presented at the display. Logically organized groups of information-chiller mode of operation, active diagnostics, settings and reports put information conveniently at your fingertips.

Tracer™ TU

The TD7 operator interface allows for daily operation tasks and setpoint changes. However to adequately service Sintesis CGAF chillers, Tracer™ TU service tool is required (Non-Trane personnel, contact your local Trane office for software purchase information). TracerTU adds a level of sophistication that improves service technician effectiveness and minimizes chiller downtime. This portable PC-based service-tool software supports service and maintenance tasks.



Pre-Start Checkout

Installation Checklist

Complete this checklist as the unit is installed, and verify that all recommended procedures are accomplished before the unit is started. This checklist does not replace the detailed instructions given in the "Installation Mechanical" and "Installation Electrical" sections of this manual. Read both sections completely, to become familiar with the installation procedures, prior beginning the work.

General

When installation is complete, before starting the unit, the following prestart procedures must be reviewed and verified:

Caution : Follow proper lockout/tagout procedures to ensure the power can not be inadvertently energized. Failure to disconnect power before servicing could result in death or serious injury

WARNING Live Electrical Components!

During installation, testing, servicing and troubleshooting of this product, it may be necessary to work with live electrical components. Have a qualified licensed electrician or other individual who has been properly trained in handling live electrical components perform these tasks. Failure to follow all electrical safety precautions when exposed to live electrical components could result in death or serious injury.

1. Inspect all wiring connections in the compressor power circuits (disconnects, terminal block, contactors, compressor junction box terminals and so forth) to ensure they are clean and tight.
2. Open all refrigerant valves in the discharge, liquid, and oil return lines.
3. Check the power-supply voltage to the unit at the main-power fused-disconnect switch. Voltage must be within the voltage use range and also stamped on the unit nameplate. Voltage fluctuation must not exceed 10%. Voltage imbalance must not exceed 2%
4. Check the unit power phasing L1-L2-L3 in the starter to ensure that it has been installed in a "A-B-C" phase sequence.
5. Fill the evaporator chilled-water circuit. Vent the system while it is being filled. Open the vents on the top while filling and close when filling is completed.
6. Close the fused-disconnect switch(es) that supplies power to the chilled-water pump starter.
7. Start the chilled-water pump to begin circulation of the water. Inspect all piping for leakage and make any necessary repairs.
8. With water circulating through the system, adjust the water flow and check the water pressure drop through the evaporator.
9. Adjust the chilled-water flow switch for proper operation.
10. Reapply power to complete the procedures
11. Prove all Interlock and Interconnecting Wiring Interlock and External as described in the Electrical Installation section.

12. Check and set, as required, all UC800TD7 menu items.
13. Stop the chilled-water pump.
14. Energize the compressor and oil separator heaters 24 hours, prior to unit start up.

Unit Voltage Power Supply

Unit voltage must meet the criteria given in the installation Electrical Section. Measure each lead of the supply voltage at the main power fused-disconnect switch for the unit. If the measured voltage on any lead is not within the specified range, notify the supplier of the power and correct the situation before operating the unit.

Unit Voltage Imbalance

Excessive voltage imbalance between the phases of a three-phase system can cause motors to overheat and eventually fail. The maximum allowable unbalance is 2%. Voltage imbalance is determined using the following calculations:

$$\% \text{ Imbalance} = [(V_x - V_{ave}) \times 100 / V_{ave}]$$

$$V_{ave} = (V_1 + V_2 + V_3) / 3$$

V_x = phase with greatest difference from *V_{ave}* (without regard to the sign)

Unit Voltage Phasing

It is important that proper rotation of the compressors be established before the unit is started. Proper motor rotation requires confirmation of the electrical phase sequence of the power supply. The motor is internally connected for clockwise rotation with the incoming power supply phases A-B-C.

When rotation is clockwise, the phase sequence is usually called "ABC"; when counterclockwise "CBA"

This direction may be reversed by interchanging any two of the line wires.

1. Stop the unit from TD7/UC800.
2. Open the electrical disconnect or circuit protection switch that provides line power to the line power terminal block(s) in the starter panel (or to the unit mounted disconnect).
3. Connect the phase-sequence indicator leads to the line power terminal block (L1-L2-L3).
4. Turn power on by closing the unit supply-power fused-disconnect switch.
5. Read the phase sequence on the indicator. The ABC LED of the phase indicator will glow.

Pre-Start Checkout

WARNING! It is imperative that L1, L2, and L3 in the starter be connected in the A-BC phase sequence to prevent equipment damage due to reverse rotation.

WARNING! To prevent injury or death due to electrocution, take extreme care when performing service procedures with electrical power energized.

CAUTION! Do not interchange any load leads that are from the unit contactors or the motor terminals. Doing so may damage the equipment.

Water System Flow Rates

Establish a balanced chilled-water flow through the evaporator. The flow rates should be between the minimum and maximum values given on the pressure drop curves.

Water System Pressure Drop

Measure the water-pressure drop through the evaporator on the field installed pressure taps on the system water piping. Use the same gauge for each measurement. Do not include valves, strainers, or fittings in the pressure drop readings.

Integrated Pump Package (Optional)

Before starting up the pump, the pipe system must be thoroughly cleaned, flushed and filled with clean water. Do not start the pump until it has been vented. To ensure correct venting, open the vent screw located on the pump housing on the suction side (see next figure).

CAUTION! When using freeze inhibitor, never fill the system with pure glycol; this will damage the shaft seal. Always fill the system with diluted solution. Maximum concentration of glycol is 40% for unit with pump package.

Caution : Failure to operate pump w/o water or insert high glycol concentration will lead to premature seal damage and void the warranty.

If the chiller is installed in a humid environment or a location with high air humidity, the bottom drain hole on the pump motor should be opened. The enclosure class of the motor is then changed from IP55 to IP44. The function of the drain holes is to drain off water which has entered the stator housing with air humidity.

Figure 11 – Pump Package

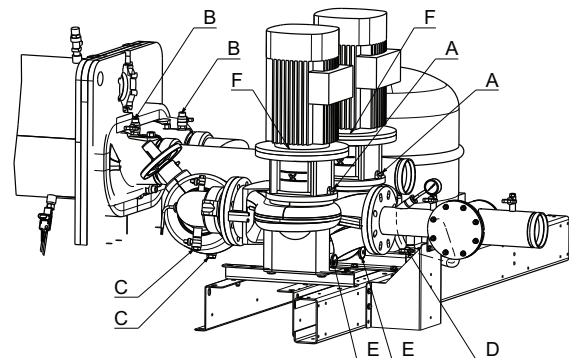

- | | |
|---------------------|---------------------------|
| A = Pump vent screw | D = Drain and fill valve |
| B = Air vent valve | E = Pump drain plug |
| C = Drain valve | F = Motor drain hole plug |

Pre-Start Checkout

Minimal installation water content

The water volume is an important parameter because it allows as table chilled water temperature and avoids short cycle operation of the compressors.

Parameters which influence the water temperature stability

- Water loop volume
- Load fluctuation
- Number of capacity steps
- Compressors rotation
- Dead band (adjusted on chiller controller)
- Minimum time between 2 starts of a compressor

Minimum water volume for a comfort application

For comfort application we can allow water temperature fluctuation at part load. The parameter to take into account is the minimum operating time of the compressor. In order to avoid lubrication problem on a scroll compressor it must run at least 2 minutes (120 seconds) before it stops.

The minimum volume can be determined by using the following formula:

Volume = Cooling capacity x Time x highest capacity step (%) / Specific heat / Dead band
 Minimum operating time = 120 seconds
 Specific heat = 4.18 kJ / kg
 Average Dead band = 3°C (or 2°C)

Note: To estimate the biggest step, it is usually more reliable to make a selection at lower ambient temperature where efficiency is higher and compressors steps bigger. It is also essential to take into account the brine specific heat, in case of the use of glycol. Process applications will need more water volume to minimize the water temperature fluctuation at part load.

Expansion tank (option)

The factory-installed expansion tank initial pressure should be adjusted about 0.2 bar lower than the static pressure of the circuit at the pump inlet. The expansion tank volume has been selected for typical loop volume. It is recommended to check the expansion tank volume with the installation information.

The following data is required:

- C = Water capacity of the circuit
- e = Expansion coefficient (difference between max and min water temperature, in operation or not)
- Pi = Initial pressure of the expansion tank
- Pf = Final pressure: Max is given by the pressure relief valve

Minimum Volume of expansion tank = $(C \times e) / (1 - P_i / P_f)$

Expansion coefficient of water various temperatures

°C	e
0	0.00013
10	0.00027
20	0.00177
30	0.00435
40	0.00728
50	0.01210

Water loop and expansion tank volume

- Water loop CGAF 080 HE/XE, CGAF 090: **607 l**
- Water loop CGAF 140-190: **777 l**

Expansion tank volume (option): **80 l**

Note:

Maximum pressure of the circuit is 400 kPa with pump package and 1000 kPa without.

Tracer UC800 Set-Up

Using TracerTU service tool, adjust the settings. Refer to TracerTU manual and UC800 user guide for instruction on settings.

CAUTION! To prevent compressor damage, do not operate the unit until all refrigerant valves and oil-line service valves are opened.

IMPORTANT! A clear sight glass alone does not mean that the system is properly charged. Also check system discharge superheat, approach temperature and unit operating pressures.

Unit Start Up Procedures

Daily Unit Start Up

The timeline for the sequence of operation begins with a power-up of the main power to the chiller. The sequence assumes 2 circuits, 2 compressors, Sintesis air cooled CGAF chiller with no diagnostics or malfunctioning components. External events such as the operator placing the chiller in AUTO or STOP, chilled water flow through the evaporator, and application of load to the chilled-water loop causing loop water-temperature increases, are depicted and the chiller responses to those events are shown, with appropriate delays noted. The effects of diagnostics, and other external interlocks other than evaporator water-flow proving, are not considered. Note: unless the UC800 TD7 and building automation system are controlling the chilled-water pump, the manual unit start sequence is as follows. Operator actions are noted.

General

If the present checkout, as discussed above, has been completed, the unit is ready to start.

1. Press the STOP key on the TD7 display.
2. As necessary, adjust the set point values on the TD7 menus using TracerTU.
3. Close the fused-disconnect switch for the chilled-water pump. Energize the pump(s) to start water circulation
4. Check the service valves on the discharge line, suction line, oil line, and liquid line for each circuit. These valves must be open (back seated) before starting the compressors.
5. Verify that chilled-water pump runs for at least one minute after the chiller is commanded to stop (for normal chilled-water systems).
6. Press the AUTO key. If the chiller control calls for cooling, and all safety interlocks are closed, the unit will start. The compressor(s) will load and unload in response to the leaving chilled – water temperature;

After the system has been operating for approximately 30 minutes and has become stabilized, complete the remaining start up procedures, as follows:

1. Check the evaporator refrigerant pressure and the condenser refrigerant pressure under Refrigerant Report on the TD7.
2. Check the EXV sight glasses after enough time has elapsed to stabilize the chiller. The refrigerant flow through the sight glasses should be clear. Bubbles in the refrigerant indicate either low refrigerant charge or excessive pressure drop in the liquid line, or an expansion valve that is stuck open. A restriction in the line can sometimes be identified by a noticeable temperature differential between the two sides of the restriction. Frost will often form on the line at this point. Proper refrigerant charges are shown in the General Information Section;

Seasonal Unit Startup Procedure

1. Close all valves and reinstall the drain plugs in the evaporator.
2. Service the auxiliary equipment according to the startup and maintenance instructions provided by the respective equipment manufacturers.
3. Close the vents in the evaporator chilled-water circuits.
4. Open all the valves in the evaporator chilled-water circuits.
5. Open all refrigerant valves.
6. If the evaporator was previously drained, vent and fill the evaporator and chilled-water circuit. When all air is removed from the system (including each pass), install the vent plugs in the evaporator water boxes.
7. Check the adjustment and operation of each safety and operating control.
8. Close all disconnect switches.
9. Refer to the sequence for daily unit start up for the remainder of the seasonal start up.

CAUTION! Ensure that the compressor and heaters have been operating for a minimum of 24 hours before starting. Failure to do so may result in equipment damage.

System Restart after Extended Shutdown

1. Verify that the liquid-line service valves, compressor discharge service valves, and optional suction service valves are open (back seated).
2. Check the oil level (see Maintenance procedures section).
3. Fill the evaporator water circuit. Vent the system while it is being filled. Open the vent on the top of the evaporator while filling, and close it when filling is completed.
4. Close the fused-disconnect switches that provide power to the chilled-water pump.
5. Start the evaporator water pump and, while water is circulating, inspect all piping for leakage. Make any necessary repairs before starting the unit.
6. While the water is circulating, adjust the water flow and check the water pressure drops through the evaporator. Refer to "water-system flow rates" and "water-system pressure drop"
7. Adjust the flow switch on the evaporator piping for proper operation
8. Stop the water pump. The unit is now ready for startup as described "Startup procedures"



Unit Start Up Procedures

CAUTION! To prevent damage to the compressor, ensure that all refrigerant valves are open before starting the unit. Do not use untreated or improperly treated water. Equipment damage may occur.

Temporary Shutdown and Restart

Temporary Shutdown is used for control operation, maintenance or to repair the unit typically less than one week.

To shut the unit down for a short time, use the following procedure:

1. Press the STOP key on the TD7. The compressors will stop when the compressor contactors de-energize.
2. Stop the water circulation by turning off the chilled water pump at least one minute after the stop of the compressors.

To restart the unit after a temporary shutdown, enable the chilled-water pump and press the AUTO key.

The unit will start normally, provided the following conditions exist:

- The UC800 receives a call for cooling and the differential-to-start is above the set point
- All system operating interlocks and safety circuits are satisfied

CAUTION! Under freezing conditions, the chilled water pump must remain in operation during the full shutdown period of the chiller if the chilled water loop does not contain glycol, to prevent any risk of evaporator freeze-up.

Extended Shutdown Procedure

The following procedure is to be followed if the system is to be taken out of service for an extended period of time (i.e. seasonal shutdown):

1. Test the unit for refrigerant leaks and repair as necessary
2. Open the electrical disconnect switches for the chilled-water pump. Lock the switches in the "OPEN" position.
3. Close all chilled-water supply valves. Drain the water from the evaporator.
4. Open the unit main electrical disconnect and unit-mounted disconnect (if installed) and lock in the "OPEN" position.
5. At least every three months (quarterly), check the refrigerant pressure in the unit to verify the refrigerant charge integrity.

CAUTION! Lock the chilled-water pump disconnects open to prevent pump damage. Lock the disconnect switch in the "OPEN" position to prevent accidental startup and damage to the system when it has been set up for extended shutdown.

During an extended shutdown period, especially over the winter season, the evaporator must be drained of water, if the chilled water loop does not contain glycol, to prevent any risk of evaporator freeze-up.

Periodic Maintenance

General

Perform all maintenance procedures and inspections at the recommended intervals. This will increase the life of the chiller and minimize the possibility of costly failures.

Weekly Maintenance

After the unit has been operating for approximately 30 minutes and the system has stabilized, check the operating conditions and complete the procedures below:

1. Check on the TD7 pressure for evaporator, condenser, and intermediate oil.
2. Inspect the entire system for unusual conditions and inspect the condenser coils for dirt and debris. If the coils are dirty, refer to coil cleaning.

Check the electronic expansion valve sight glasses. (Note: The electronic expansion valve is commanded closed at unit shutdown and if the unit is off, there will be no refrigerant flow through the sight glasses. Only when a circuit is running will refrigerant flow be present.) The refrigerant flow through the sight glasses should be clear. Bubbles in the refrigerant indicate either low refrigerant charge or excessive pressure drop in the liquid line. A restriction in the line can sometimes be identified by a noticeable temperature differential between the two sides of the restriction. Frost may often form on the liquid line at this point. Correct refrigerant charges is shown in nameplate.

NOTICE: A clear sight glass alone does not mean that the system is properly charged. Also check the system superheat, subcooling and unit operating pressures.

NOTICE: Use only manifold gauge sets designed for use with R410A refrigerant.

Use only recovery units and cylinders designed for the higher pressure of R410A refrigerant and POE oil.

NOTICE: R410A must be charged in a liquid state.

Check the system superheat, subcooling, evaporator temperature drop (Delta-T), evaporator water flow, evaporator approach temperature, compressor discharge superheat, and compressor RLA.

Normal operating conditions at ISO conditions are:

Evaporator pressure: 8 bars

Evaporator Approach: 3-5°C

Evaporator Superheat: 6-7°C

Electronic Expansion Valve: 30-50 percent open

Evaporator Temperature Drop (Delta-T): 5°C

Condensing Pressure: 28-32 bars

Condensing Approach Temperature: 14-18°C

System Subcooling: 8-12°C

If operating pressures and sight glass conditions seem to indicate a refrigerant shortage, measure the system superheat and subcooling.

Refer to "System Superheat" and "System Subcooling."

If operating conditions indicate a refrigerant overcharge, remove refrigerant at the liquid line service valve. Allow refrigerant to escape slowly to minimize oil loss. Use a refrigerant recovery cylinder and do not discharge refrigerant into the atmosphere.

WARNING!

Do not allow refrigerant to directly contact skin as injury from frostbite may result.

Monthly Maintenance

1. Perform all weekly maintenance procedures.
2. Record the system subcooling.
3. Make any repairs necessary.

Annual Maintenance

1. Perform all weekly and monthly procedures
2. Check the oil sump oil level while the unit is off.

Note: Routine changing of the oil is not required. Make an oil analysis to determine the condition of the oil.

1. Have Trane or another qualified laboratory perform a compressor oil analysis to determine system moisture content and acid level. This analysis is a valuable diagnostic tool.
2. Contact a qualified service organization to leak-test the chiller, to check operating and safety controls, and to inspect electrical components for deficiencies.
3. Inspect all piping components for leakage and damage.
4. Clean and repaint any areas that show signs of corrosion.
5. Clean the condenser coils.
6. Check and tighten all electrical connections as necessary.

CAUTION! A clear sight glass alone does not mean that the system is properly charged. Also check the rest of the system operating conditions.

WARNING! Position all electrical disconnects in the "Open" position and lock them to prevent injury or death due to electrical shock.

Periodic Maintenance

Refrigerant Emission Control

Conservation and emission reduction can be accomplished by following recommended Trane operation, maintenance, and service procedures, with specific attention to the following:

1. Refrigerant used in any type of air-conditioning or refrigerating equipment should be recovered and/or recycled for reuse, reprocessed (reclaimed). Never release refrigerant into the atmosphere.
2. Always determine possible recycle or reclaim requirements of the recovered refrigerant before beginning recovery by any method.
3. Use approved containment vessels and safety standards. Comply with all applicable transportation standards when shipping refrigerant containers.
4. To minimize emissions while recovering refrigerant, use recycling equipment. Always attempt to use methods that will pull the lowest possible vacuum while recovering and condensing refrigerant into containment.
5. Refrigerant-system cleanup methods that use filters and dryers are preferred. Do not use solvents that have ozone depletion factors. Properly dispose of used materials.
6. Take extra care to properly maintain all service equipment that directly supports refrigeration service work, such as gauges, hoses, vacuum pumps, and recycling equipment.
7. Stay aware of unit enhancements, conversion refrigerants, compatible parts, and manufacturer's recommendations that will reduce refrigerant emissions and increase equipment operating efficiencies. Follow the manufacturer's specific guidelines for conversion of existing system.
8. In order to assist in reducing power-generation emissions, always attempt to improve equipment performances with improved maintenance and operations that will help conserve energy resources.

Refrigerant and Oil-charge Management

Proper oil and refrigerant charge is essential for proper unit operation, unit performances, and environmental protection. Only trained and licensed service personnel should service the chiller.

Some of the symptoms of a refrigerant under-charged unit:

- Larger-than-normal evaporator approach temperatures (leaving water temperature – saturated evaporator temperature). If the refrigerant charge is correct the approach temperature is 5°C. These values are given for units running at full load and with water without antifreeze
- Low Evaporator-refrigerant temperature limit
- Low Refrigerant-Temperature cutout diagnostic
- Fully-open expansion valve
- Possible whistling sound coming from liquid line (due to high vapor velocity)
- High condenser + Subcooler pressure drop

Some of the symptoms of a refrigerant over-charged unit

- Condenser Pressure Limit
- High –Pressure Cutout diagnostic
- More-than-normal number of fans running
- Erratic fan control
- Higher-than-normal compressor power

Some of the symptoms of an oil over-charged unit

- Larger-than-normal evaporator approach temperatures (Leaving-water-temperature – Saturated Evaporator Temperature)
- Low Evaporator-refrigerant Temperature limit
- Low Refrigerant – Temperature Cutout diagnostic
- Low unit capacity
- High oil-sump level after normal shutdown

Some of the symptoms of an oil under-charged unit

- Seized or Welded compressors
- Low oil-sump level after normal shutdown

Compressor Maintenance

Compressor Electrical Connections

It is very important that DSH compressors used in Trane Model CGAF chillers are wired correctly for proper rotation. These compressors will not tolerate reverse rotation. Verify correct rotation/phasing using a rotation meter.

Proper phasing is clockwise, A-B-C. If wired incorrectly a DSH compressor will make excessive noise, will not pump and will draw about half the normal current. It will also become very hot if allowed to run for an extended period.

Notice: Do not “bump” the compressor to check rotation as incorrect rotation could cause compressor motor failure in as little as 4 to 5 seconds!

Oil Level

To check compressor oil level, refer to the label near the compressor sight glass. The compressor(s) must be off. Wait three minutes. With tandem or triple compressors the oil level will equalize after shutdown. Compressor oil level should be no lower than the bottom of the sight glass and no more than a full sight glass. When operating, each compressor in a tandem or trio set may have a different oil level. The oil level may not be in the sight glass, but it must be visible through the sight glass.

Oil Fill, Removal and Capacity

The Model DSH compressors have an oil charging valve with a dip tube that goes to the bottom of the compressor. This can be used to add or remove oil from the compressor.

Care must be taken to prevent moisture from entering the systems when adding oil. Note that the POE oil used in this product is very hygroscopic and easily absorbs and retains moisture. Moisture is very difficult to remove from oil using vacuum. Also note that once the seal on a container of POE oil is opened, the oil must be used.

Use only Trane OIL0057 (3.8 l) or OIL00058E (18.9 l). These are the same oil but different container size. Do not use any other POE oil.

NOTE: Never reuse oil.

Oil Testing

We recommend performing a complete oil analysis at least once a year with the Trane laboratory specifically dedicated to oil analysis for Trane equipment. It provides an in-depth view of both compressor and refrigerant circuit conditions including presence of water, wear particles, viscosity, acidity or dielectric data. If unacceptable wear conditions develop, a change in the characteristics of the oil will be evident. Minor problems can be detected and repaired before they become major problems.



Compressor Maintenance

Oil Equalizer Line

DSH Compressors

The oil equalizer line is equipped with a Rotolock fitting for easy removal. Torque value for tightening these fitting is 145 N.m Drain the oil to a level below the oil equalizer tube fitting before removing the oil equalizer line. This must be done on both compressors. Use the oil drain valve on the compressor. If the oil is drained below the level of the oil level sight glass, it will be below the oil equalizer line level. Pressurize the low side of the compressor using nitrogen to help drain the oil. No more than 70 kPa of pressure will be needed.

Tandem and Triple Compressor Suction Restrictors

Since most tandem and triple compressor sets use unequal size compressors, these combinations require the use of a restrictor in the suction line of one or more compressors in order to provide correct oil level balance between compressors when they are operating.

Compressor Replacement

If the CGAF chiller suffers a failed compressor, use these steps for replacement:

Each compressor has lifting eyes. Both lifting eyes must be used to lift the failed compressor. **DO NOT LIFT A COMPRESSOR USING A SINGLE LIFTING EYE.** Use proper lifting techniques, a spreader bar and rigging as for lifting both compressors simultaneously.

After a mechanical failure of a compressor, it is necessary to change the oil in the remaining compressor and also replace the liquid line filter drier. After an electrical failure of a compressor, it will also be necessary to change the oil in the remaining compressor, replace the liquid line filter drier and add a suction filter drier with clean-up cores.

Note: Do not alter the refrigerant piping in any way as this can affect compressor lubrication.

Refrigerant System Open Time

Model CGAF chillers use POE oil and therefore refrigerant system open time must be kept to a minimum. The following procedure is recommended:

Leave a new compressor sealed until it is ready to be installed in the unit. Maximum system open time is dependent upon ambient conditions, but do not exceed one hour open time.

Plug the open refrigerant line to minimize moisture absorption. Always change the liquid line filter drier.

Evacuate the system to 500 microns or below.

Do not leave POE oil containers open to the atmosphere. Always keep them sealed.

Mechanical Compressor Failure

Replace the failed compressor(s) and change the oil in the remaining compressor(s) along with the refrigerant system liquid line filter drier.

Compressor Maintenance

Electrical Compressor Failure

Replace the failed compressor and change the oil in the other compressor(s). Also add a suction filter with cleanup cores and change the liquid line filter drier. Change filters and oil until the oil no longer test acidic. See "Oil Testing."

Compressor Motor Megging

Motor megging determines the electrical integrity of the compressor motor winding insulation. Use a 500 volt megger. A less than 1 meg-ohm reading is acceptable and 1000 ohms per nameplate volts is required to safely start the compressor.

Compressor Current Imbalance

Normal current imbalance could be 4 to 15 percent with balanced voltage due to motor design. Each phase should register 0.3 to 1.0 ohms and each phase should be within 7 percent of the other two phases. Phase to ground resistance must be infinity.

NOTICE: Maximum allowable voltage imbalance is 2 percent.

Refrigerant Piping

The compressor suction and discharge connections and piping are copper clad steel for easy brazing. In most instances, piping may be reused. If piping is not reusable, order the correct service parts. Cut all tubing with a tubing cutter to prevent copper filings from entering the system. Cut the tubing in a straight length of pipe after the compressor connection has been unsweated. The line can then be reinstalled using a slip coupling and brazing.

NOTICE: The compressor suction line configuration must not be changed in any way. Changing compressor suction line configuration will compromise proper oil return to the compressor(s).

Compressor Electrical Terminal Box

Be sure to protect the terminal box when unbrazing or brazing compressor refrigerant piping connections

Compressor Crankcase Heaters

Compressor crankcase heaters must be energized at least eight hours before starting the CGAF chiller. This is required to boil refrigerant out of the oil before startup. Ambient temperature is not a factor and the crankcase heaters must always be energized prior to startup.

MCHE Condenser Coils Maintenance

Cleaning Procedures

- It is mandatory to clean regularly the coils for a proper unit operation. Eliminate pollution and other residual material help to extend the life of the coils and the unit

CAUTION! Equipment Damage! Do not use coil cleaning agents to clean uncoated CGAF coils. Use clean water only. Use of coil cleaning agents on uncoated CGAF coils could cause damage to coils.

- Regular coil maintenance, including annual cleaning-enhances the unit's operating efficiency by minimizing compressor head pressure and amperage draw. The condenser coil should be cleaned at least once each quarter or more if the unit is located in a "dirty" or corrosive environment. Unless it is the Trane cleaner part reference CHM014E cleaning with cleansers or detergents is strongly discouraged due to the all-aluminum construction; straight water should prove sufficient. Any breach in the tubes can result in refrigerant leaks

Important: Only in extreme cases should any type of chemical cleaner or detergent be used on microchannel coils. If it becomes absolutely necessary because water alone did not clean the coil, specify a cleaner that is:

- A is pH neutral cleaner.
- An alkaline cleaner that is no higher than 8 on the pH scale.
- An acidic cleaner that is no lower than 6 on the pH scale.
- Does not contain any hydrofluoric acids.

Be sure to follow the instructions provided with any cleaner chosen. Keep in mind that it is still **MANDATORY** that the coils are thoroughly rinsed with water after the application of the cleaner even if the instructions specify a "No Rinse" cleaner. Cleaners or detergents that are left on the coil due to improper rinsing will significantly increase the possibility of corrosion damage on the microchannel coil.

Note: Quarterly cleaning is essential to extend the life of an E-coated coil and is required to maintain warranty coverage. Failure to clean an E-coated coil will void the warranty and may result in reduced efficiency and durability in the environment.

WARNING! Hazardous Voltage!

Disconnect all electric power, including remote disconnects before servicing. Follow proper lockout/tagout procedures to ensure the power cannot be inadvertently energized. Failure to disconnect power before servicing could result in death or serious injury.

1. Disconnect Power to the unit.
2. Wear proper personal protection equipment such as a face shield, gloves and waterproof clothing.
3. Remove enough panels from the unit to gain safe access to the microchannel coil.

Note: It is better to clean the coil from the opposite direction of normal air flow (inside of unit out) because this allows the debris to be pushed out rather than forced further into the coil.

4. Use a soft brush or vacuum to remove base debris or surface loaded fibers from both sides of the coil.

Note: Remove solid residue is essential to preserve performance of the coil and avoid corrosion over the length of the product life.

5. Using a sprayer and water ONLY, clean the coil following the guidelines below.
 - a. Sprayer nozzle pressure should not exceed 40 bars.
 - b. The maximum source angle should not exceed 25 degrees (Figure 22) to the face of the coil. For best results spray the microchannel perpendicular to face of the coil.
 - c. Spray nozzle should be approximately 5 to 10 cm from the coil surface.
 - d. Use at least a 15° fan type of spray nozzle.

Figure 12 – Sprayer source angle

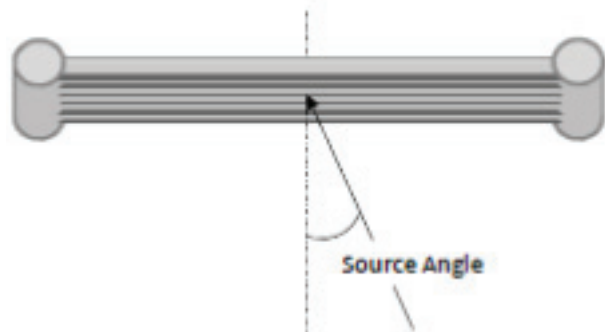

To avoid damage from the spray wand contacting the coil, make sure the 90° attachment does not come in contact with the tube and fin as abrasion to the coil could result.

Repair/Replacement of Microchannel Coil

Microchannel coils are considerably more robust in design than tube and fin condenser coils, however they are not indestructible. When damage or a leak occurs in the field, it is possible to temporarily repair the coil until another coil can be ordered.

If the leak is found to be within the tube area of the coil, a field repair kit (KIT16112) is available through your local Trane parts center. Because of the all-aluminum construction and aluminum's high thermal expansion rate, a leak located at or on the header assembly cannot be repaired.

Integrated Pump Maintenance

Optional Water Pump Maintenance

CAUTION! The lifting eyebolts of the motor are suitable for the weight of the motor only. It is not allowed to carry the complete pump on the lifting eyebolts of the motor.

Lubrication

The bearings of motors 5.5kW and 7.5kW are greased for life and require no lubrication. The pump shaft seal does not require any special maintenance. Visual leakage check are however required. Distinctly visible leakage will require an exchange of the seal.

The bearing of motors 11kW and up must be greased every 4000 hours or at yearly service. The required grease quantity is 10g per bearing. The motor must run during lubrication.

Use lithium-based grease.

For further details about pump maintenance please consult the pump supplier website.

Figure 13 – Motor bearings

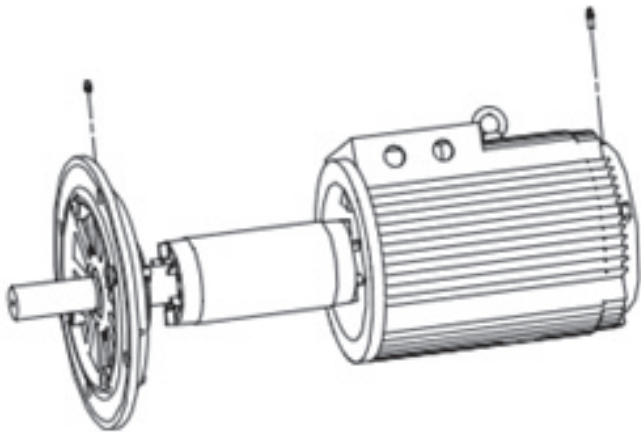



Log Check Sheet

The operator log sheet are included for use as appropriate, for installation completion verification before Trane Start-up is scheduled, and for reference during the Trane Start-up.

Operator Log				
Sintesis CGAF chiller with UC800 Controller - Tracer AdaptiView Reports - Log Sheet				
	Start	15 minutes	30 minutes	1 hour
Evaporator				
Active Chilled Water Setpoint				
Entering Water Temperature				
Leaving Water Temperature				
Ckt 1				
Saturated Refrigerant Temperature (°C)				
Refrigerant Pressure (kPa)				
Approach Temperature (°C)				
Water flow Status				
EXV % Open				
Ckt 2				
Saturated Refrigerant Temperature (°C)				
Refrigerant Pressure (psia)				
Approach Temperature (°C)				
Water flow Status				
EXV % Open				
Condenser				
Outdoor Temperature				
Ckt 1				
Air flow (%)				
Saturated Refrigerant Temperature (°C)				
Refrigerant Pressure (kPa)				
Subcooling in °C				
Ckt 2				
Air flow (%)				
Saturated Refrigerant Temperature (°C)				
Refrigerant Pressure (kPa)				
Subcooling in °C				
Compressor 1A				
Running Status				
Starts				
Running Time (Hr:min)				
Oil Pressure (kPa)				
Compressor 1B				
Running Status				
Starts				
Running Time (Hr:min)				
Oil Pressure (kPa)				
Compressor 2A				
Running Status				
Starts				
Running Time (Hr:min)				
Oil Pressure (psia)				
Compressor 2B				
Running Status				
Starts				
Running Time (Hr:min)				
Oil Pressure (psia)				
Compressor 3A				
Running Status				
Starts				
Running Time (Hr:min)				
Oil Pressure (psia)				
Compressor 3B				
Running Status				
Starts				
Running Time (Hr:min)				
Oil Pressure (psia)				
Date:				
Technician:				
Owner:				

Recommended service routine frequencies

As a commitment to our customers, we have created a wide service network staffed with experienced factory-authorized technicians. At Trane we offer all the benefits of after sales service direct from the manufacturer and we are committed to our mission statement to provide efficient customer care.

We would be delighted to discuss your individual requirement with you. For further information regarding Trane maintenance agreements please contact your local TRANE sales office.

Year	Commis- sioning	Inspec- tion visit	Seasonal shut down	Seasonal start up	Oil analysis (2)	Vibration analysis (3)	Annual mainte- nance	Preven- tive mainte- nance	Tube analysis (1)	Com- pressor R'newal (4)
1	x	x	x	x		x		xx		
2			x	x	x		x	xxx		
3			x	x	x		x	xxx		
4			x	x	x		x	xxx		
5			x	x	x	x	x	xxx	x	
6			x	x	x	x	x	xxx		
7			x	x	x	x	x	xxx		
8			x	x	x	x	x	xxx		
9			x	x	x	x	x	xxx		
10			x	x	x	x	x	xxx	x	
over 10			every year	every year	every year (2)	x	every year	3 every year	every 3 years	40000 h

This timetable is applicable to units operating in normal conditions with an average of 4000 hours per year. If operating conditions are abnormally severe, an individual timetable must be made for that unit.

- (1) Tube testing required if aggressive water conditions exist. Applies to condensers only on water cooled units.
- (2) Schedule as per previous analysis result or at least once a year.
- (3) Year 1 to define equipment baseline. Subsequent year based on oil analysis results or schedule as per vibration analysis.
- (4) Recommended at 40 000 run hours or 100 000 equivalent operating hours whichever comes first. Schedule also depends on results from oil analysis / vibration analysis.

Seasonal start up and shutdown are mainly recommended for comfort air conditioning. Annual and preventive maintenance are mainly recommended for Process applications.



Additional services

Oil analysis

Trane Oil Analysis is a predictive tool used to detect minor issues before they become major problems. It also reduces failure detection time and allows planning for appropriate maintenance. Oil changes can be reduced by half resulting in lower operating costs and a lower impact on the environment.

Vibration analysis

Vibration analysis is required when oil analysis reveals the presence of wear indicating the start of possible bearing or motor failure. Trane oil analysis has the ability to identify the type of metallic particles in the oil which, when combined with the vibration analysis, will clearly point out the failing components.

Vibration analysis should be performed on a regular basis to build a vibration trend of the equipment and avoid unplanned downtime and costs.

Compressor R'newal

To ensure a long lifetime for Trane compressors, system oil and vibration are regularly analyzed. These tests build a detailed picture of the condition of internal system components. Over time, they also help build a 'wear trend' of the equipment. This informs our service experts whether your compressor is due for minor maintenance or a complete overhaul.

System upgrade

This Service provides a consulting service.

Upgrading your equipment will increase the unit reliability and can reduce the operating costs by optimizing the controls. A list of solutions / recommendations to the system will be explained to the customer. Actual upgrade for the system will be costed separately.

Water treatment

This Service provides all of the necessary chemicals to properly treat each water system for the period designated.

The inspections will be conducted at agreed upon intervals and Trane Service First will submit a written report to the customer after each inspection.

These reports will indicate any corrosion, scaling, and alga growth in the system.

Refrigerant analysis

This Service includes a thorough analysis for contamination and solution upgrade.

It is recommended that this analysis be performed every six months.

Annual cooling tower maintenance

This Service includes the inspection and maintenance of the cooling tower at least once a year.

This involves checking the motor.

24 hours duty

This service includes emergency calls outside of the office normal working hours.

This Service is only available with a Maintenance Contract, where available.

Trane Select Agreements

Trane Select Agreements are programs tailored to your needs, your business and your application. They offer four different levels of coverage. From preventive maintenance plans to fully comprehensive solutions, you have the option of selecting the coverage that best suits your requirements.

5 years motor-compressor warranty

This Service will provide a 5 years part and labor warranty for the motor compressor only.

This Service is only available for units covered by a 5 years Maintenance Contract.

Tube analysis

- Eddy Current Tube Testing for prediction of tube failure/wear
- Frequency - every 5 years for first 10 years (depending on the water quality), then every 3 years thereafter.

Energy enhancement

With Trane Building Advantage you can now explore cost effective ways to optimize the energy efficiency of your existing system and generate immediate savings. Energy management solutions are not only for new systems or buildings. Trane Building Advantage offers solutions designed to unlock energy savings in your existing system.



Notes



Trane optimizes the performance of homes and buildings around the world. A business of Ingersoll Rand, the leader in creating and sustaining safe, comfortable and energy efficient environments, Trane offers a broad portfolio of advanced controls and HVAC systems, comprehensive building services and parts. For more information visit www.Trane.com

© 2017 Trane All rights reserved
CG-SVX039A-GB August 2017
New

We are committed to using environmentally
conscious print practices that reduce waste.

